

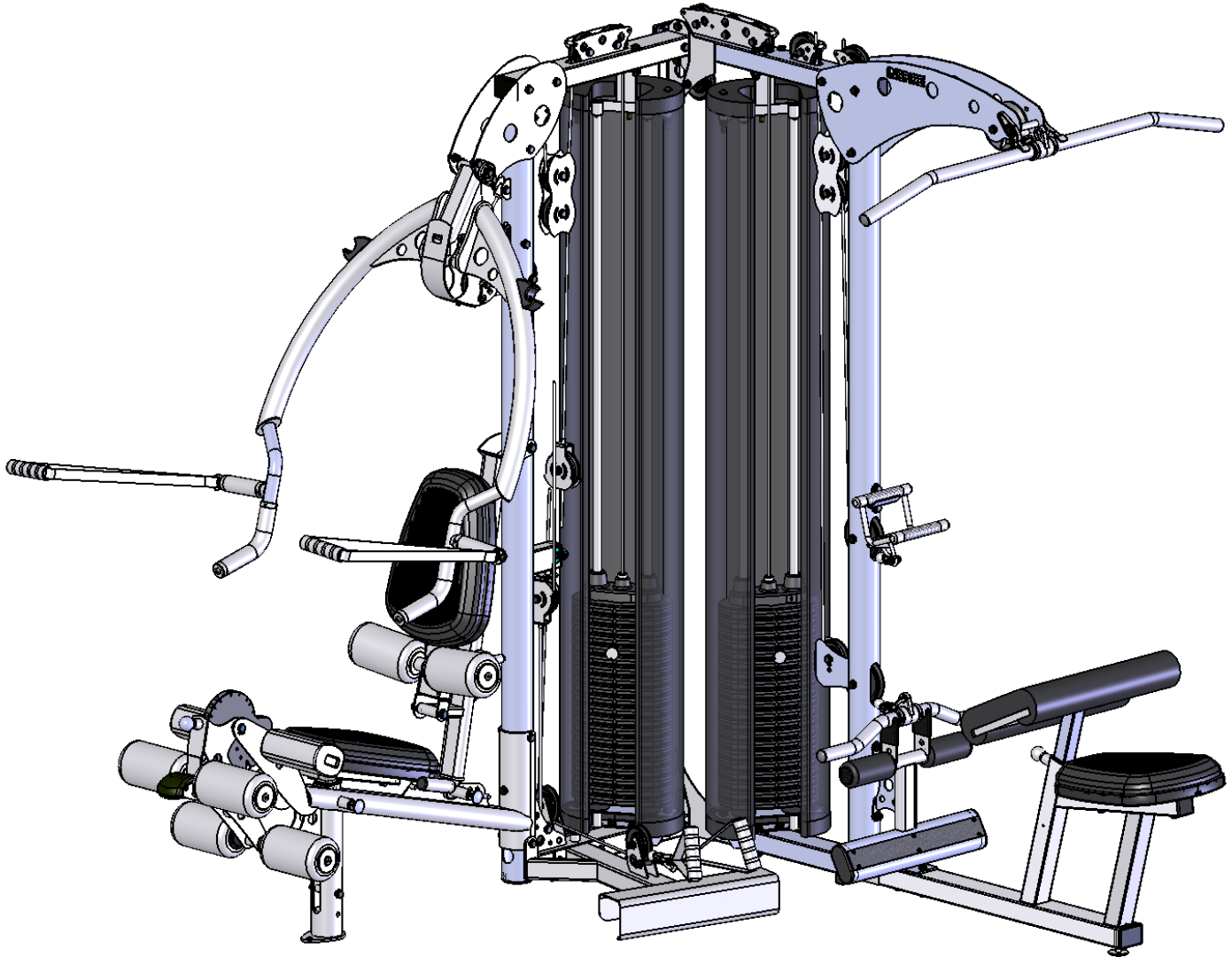

ASSEMBLY & OPERATION MANUAL



RECORD SERIAL NUMBER HERE

CONGRATULATIONS... You've just taken the first step to a healthier and stronger body. This multi-gym by Inspire offers the key to unlocking your body's potential. Regular strength training on a multi-gym has been shown to deliver a host of benefits including: increased muscle tone, decreased body fat, improved energy levels, a reduction in stress, and improved cardiac output. Once again, congratulations, you are on your way to improving your self image, overall health, and quality of life.

BEFORE ASSEMBLING YOUR HOME GYM

IMPORTANT: Read this entire manual before attempting to build or use this machine. This manual contains step by step instructions for proper assembly.

Use the parts list included in this manual to verify that all parts are accounted for before assembly. If any parts are missing, contact the retailer of this multi-gym for replacement parts. Or, call Inspire at 877-738-1729.

Make sure that adequate room has been cleared before attempting to build your multi-gym. A rubber mat is recommended for use under your multi-gym to protect wood flooring or carpeting from damage during assembly and usage.

This multi-gym is intended for indoor use only. Rust can form on certain parts including guide rods in a humid environment, resulting in impaired function.

Service of your multi-gym should only be performed by an authorized Inspire retailer. Service performed by anyone else can result in loss of warranty. If you need help finding an authorized retailer, please contact us directly:

Inspire Fitness
4945 East Hunter Avenue
Anaheim, CA 92807
Ph: 877-738-1729
Fx: 714-738-1728
www.inspirefitness.net

TABLE OF CONTENTS

Section Description.....	Page
Important Safety Instructions.....	1
Tools Required.....	1
Parts & Hardware List.....	2
Cable Chart	3
Assembly Instructions.....	4-22
Decal Reference.....	23-24
Decal Placement.....	25
Accessories.....	26
General Maintenance Information.....	27
Maintenance Schedule.....	28
Limited Warranty.....	29

IMPORTANT SAFETY INSTRUCTIONS

Please read this entire manual and familiarize yourself with all decals and warnings before using this multi-gym.

- **WARNING!** It is necessary to inspect this multi-gym regularly to maintain safety and proper function. Please use the maintenance schedule included towards the back of this manual. Immediately replace any and all defective or worn parts. Pay special attention to moving parts such as the cables and pulleys and connections to accessories. See General Maintenance section for complete details.
- Use this multi-gym for its intended purpose as described in this Operation Manual or the exercise chart. Do not use attachments not recommended by the manufacturer.
- **Do not hang from press arm. The press arm is not designed to support human weight.**
- Make sure bystanders are at least 5 feet away from the multi-gym while it is in use.
- Keep children off the multi-gym at all times.
- Keep the multi-gym away from walls and clear of any obstructions and furniture.
- Stop immediately if you experience shortness of breath, pain, or dizziness during your workout. Inspire strongly recommends consulting your doctor before starting an exercise program.

TOOLS REQUIRED FOR ASSEMBLY

- Metric socket set (including 17mm, 18mm, and 19mm sockets)
- Metric 17mm, 18mm, and 19mm wrenches
- 6mm, 5mm, and 4mm Allen wrenches (supplied in the hardware packs)
- Adjustable wrench
- Tape Measure
- Rubber Mallet

Parts & Hardware List

Item	Parts Description	Qty	Qty Rec'd
1	Main Frame, Lat Station	1	
2	Main Upright, Press Arm	1	
3	Lat Seat Frame	1	
4	Seat Base Frame	1	
5	Preacher Curl Stem	1	
6	Foot Rest Assembly	1	
7	Seat Stem Assembly	1	
8	Back Pad Mount	1	
9	Upper Shroud Mount Bracket	2	
10	Double D Low Row Handle Mount	1	
11	Lower Pulley Mount	1	
12	Press Arm Mount	1	
13	Press Arm Assembly	1	
14	Back Pad Support Frame	1	
15	Leg Extension Assembly	1	
16	Double D Low Row Handle	1	
17	Revolving Aluminum Lat Bar	1	
18	Revolving Aluminum Curl Bar	1	
19	Calf Block Attachment Arm	1	
20	Floating Pulley Bracket Assembly	1	
21	Adjustable Stop	2	
22	Top Beam Plate, Press Arm	2	
23	Top Beam Plate, Lat Station	2	
24	Pulley Bracket	1	
25	Barrel Spacer, 1" long	1	
26	Lower Guide Rod Mount	2	
27	Cam Plate	1	
28	Floating Pulley Plate	4	
29	N/A		
30	Orthopedic Pad	3	
31	Spacer Tube, 3" long	1	
32	Calf Raise Block	1	
33	Shroud Plate	4	
34	Preacher Curl Pad	1	
35	Seat Base Assembly	3	
36	Small Covered Foam Roller	2	
37	Thigh Pad	2	
38	Large Covered Foam Roller	4	
39	Covered Foam Roller with tube insert	2	
40	Press Arm Lower Cable	1	
41	Leg Extension Cable	1	
42	Press Arm Middle Cable	1	
43	Press Arm Upper Cable	1	
44	Lat Lower Cable	1	
45	Lat Upper Cable	1	
46	Step Spacer, 1" long	10	
47	N/A		
48	Leg Extension Cam Assembly	1	
49	Plastic Spacer Tube	2	
50	Aluminum Endcap	6	
51	Barrel Spacer, 5/8" long	2	
52	N/A		
53	N/A		
54	Fabric Shroud	2	
55	Cable End	2	
56	Bushing	1	

Item	Parts Description	Qty	Qty Rec'd
57	4 1/2" Pulley	2	
58	Small Pulley, Leg Extension	2	
59	3 1/2" Pulley	25	
60	4 1/2" Wide Pulley	1	
61	Cable Ball	4	
62	"U" Bracket Cable End	4	
63	N/A		
64	Press Arm Cover Plate	1	
65	Guide Rod Spacer Plate	2	
66	Press Arm Bearing Assembly	2	
67	Rubber Donut	4	
68	Lat Bar Holder	2	
69	Large Plastic Washer	4	
70	Weight Plate	40	
71	Adjustment Bumper	1	
72	Cable Adapter	2	
73	Corner Bracket	1	
74	Flat Head Nut, M6	4	
75	Button Head Bolt, M6*15	4	
76	Selector Pin	2	
77	Top Weight/Selector Stem Assembly	2	
78	Spring Clip	4	
79	N/A		
80	Washer, $\Phi 25.4 \times \Phi 10 \times 2$	14	
81	N/A		
82	End Cap	2	
83	Flat Head Bolt, M10*25	6	
84	Button Head Bolt, M5*12	1	
85	Hex Nut, M12	2	
86	Flat Washer, $\phi 10$	159	
87	Flat Washer, $\phi 12$	7	
88	Curved Washer, $\phi 10$	4	
89	Thin Locknut, M12, h=8mm	1	
90	Locknut, M10	77	
91	Locknut, M12	3	
92	Hexagon Bolt, M10*115	1	
93	Hexagon Bolt, M10*100	8	
94	Hexagon Bolt, M10*45	22	
95	Button head Bolt, M10*20	2	
96	Hexagon Bolt, M10*50	4	
97	Hexagon Bolt, M10*95	11	
98	Hexagon Bolt, M12*95	2	
99	Hexagon Bolt, M12*110	1	
100	Hexagon Bolt, M10*105	3	
101	Hexagon Bolt, M10*110	1	
102	Hexagon Bolt, M10*70	13	
103	Flat Head Bolt, M10*70	2	
104	Hexagon Bolt, M10*60	4	
105	Hexagon Bolt, M10*35	4	
106	Hexagon Bolt, M10*20	16	
107	Hexagon Bolt, M12*150	1	
108	Hexagon Bolt, M10*25	5	
109	N/A		
110	Hex Key Wrench, 6mm	1	
111	Hex Key Wrench, 5mm	2	
112	Hex Key Wrench, 4mm	1	
113	Thin Locknut, M10 , h=8mm	4	

CABLE CHART

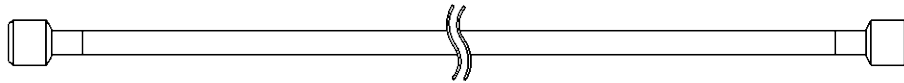

Press Arm Upper Cable
Cable Number 870-500-004

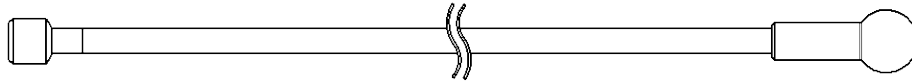

Leg Extension Cable
Cable Number 870-500-002

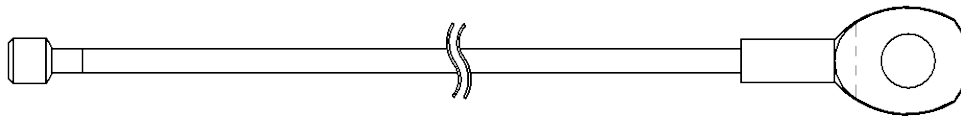

Press Arm Middle Cable
Cable Number 870-500-003

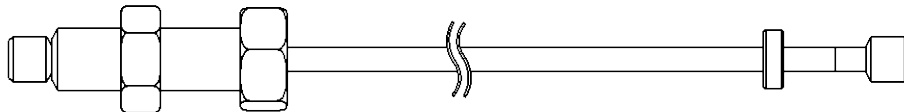

Press Arm Lower Cable
Cable Number 870-500-001

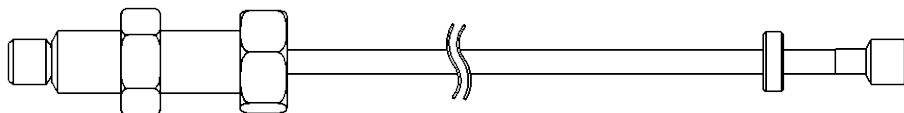

Lat Upper Cable
Cable Number 870-500-006

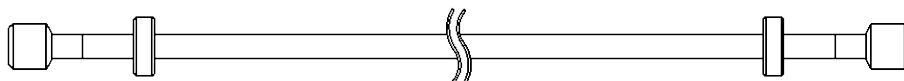

Lat Lower Cable
Cable Number 870-500-005

ASSEMBLY INSTRUCTIONS

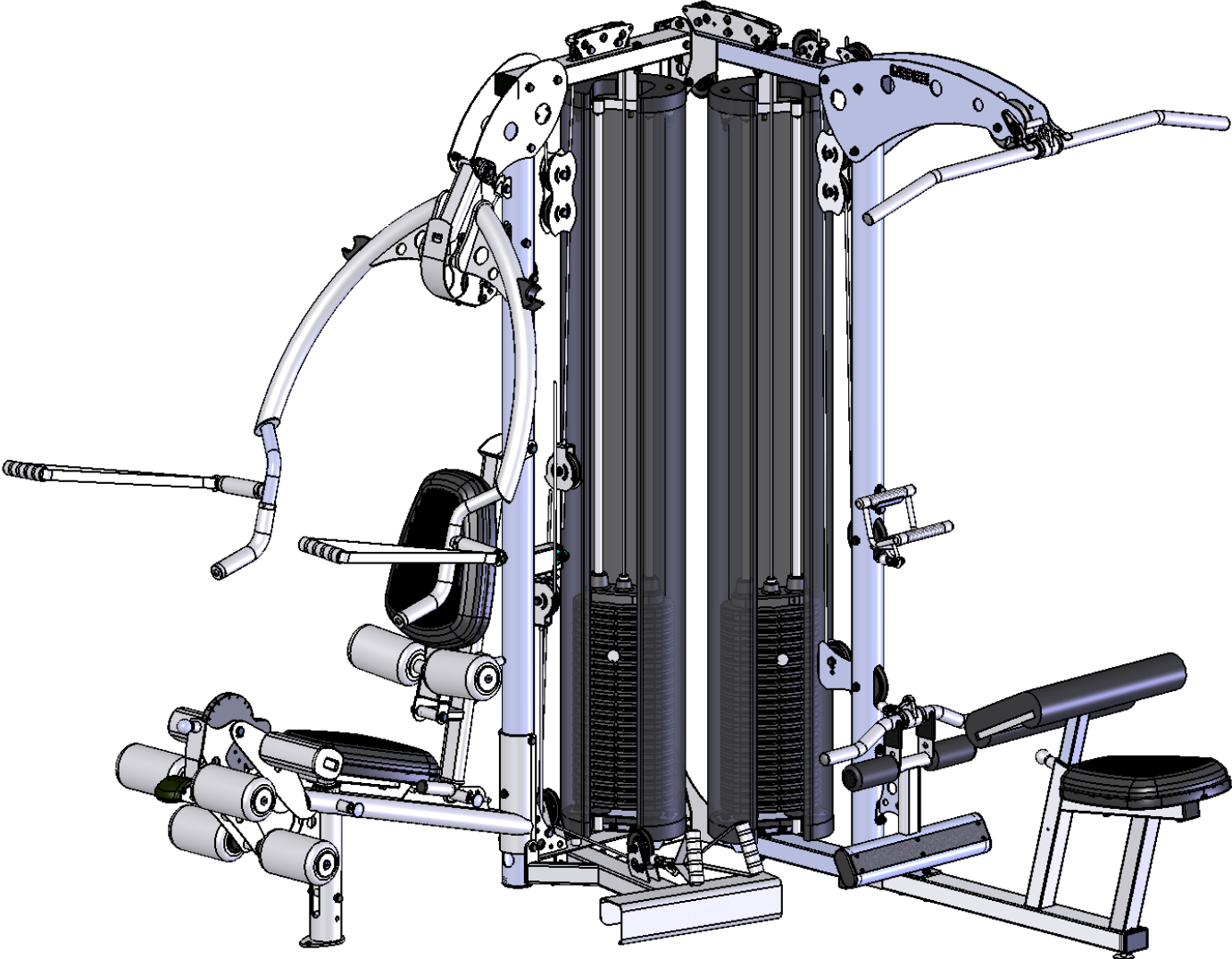

STEP 1

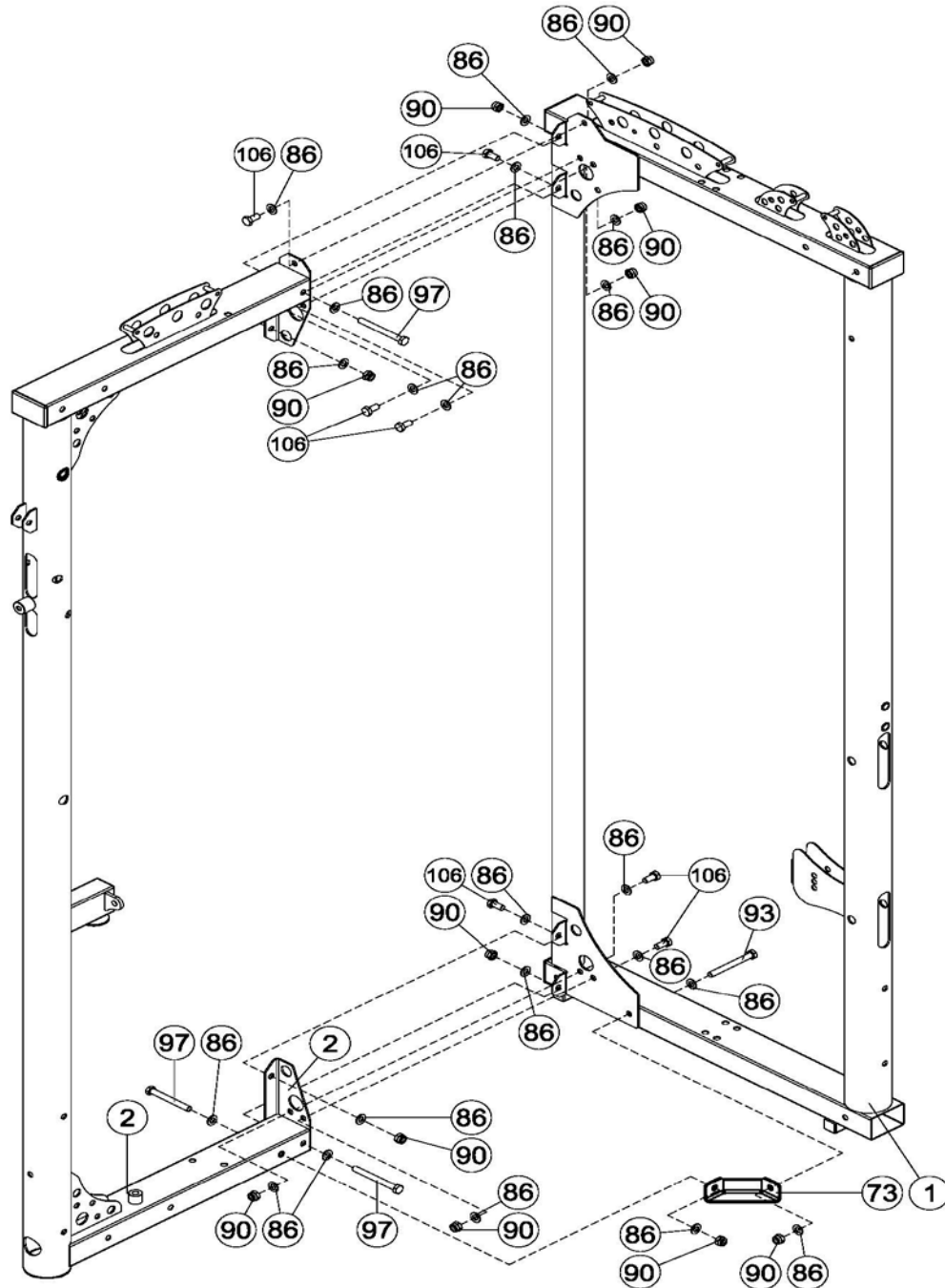

This step requires two people to be completed safely

- A) Place the Main Frame (1) and the Main Upright (2) as shown and attach them using the M10*95 bolts (97) and M10*20 bolts (106).
- B) Attach the Corner Bracket (73) to the two frames using a M10*95 bolt (97) and M10*100 bolt (93).

Tighten all the hardware at this time.

STEP 2

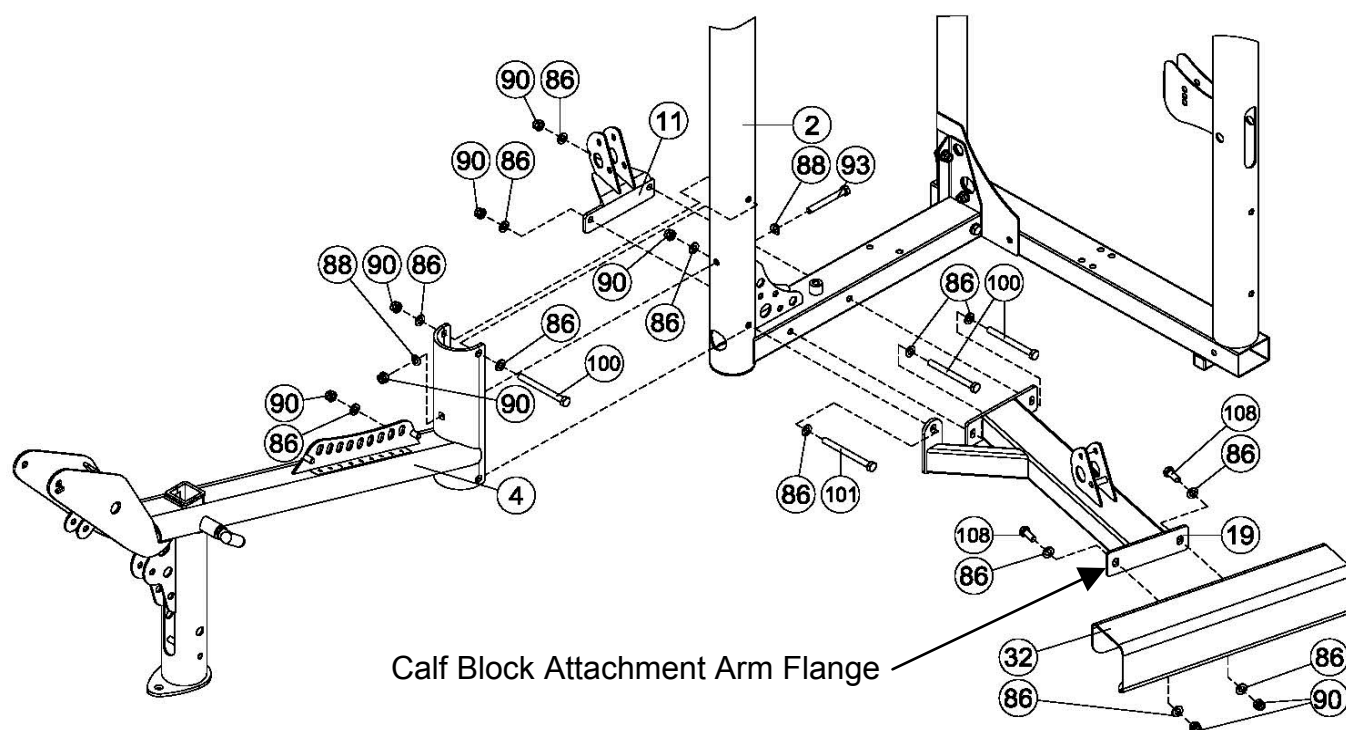

Do not tighten any hardware in Step 2 until specifically instructed.

- A) Using the M10*100 bolt (93) attach the Seat Base Frame (4) to the Main Upright (2).
- B) Insert the M10*105 bolt (100) above the M10*100 bolt (93) in Step 2A.
- C) Attach the Calf Raise Block (32) to the Calf Block Attachment Arm (19) using the M10*25 bolts (108). The flange on the Calf Block Attachment Arm should be positioned on the inside of the Calf Raise Block.
- D) Attach the Calf Block Attachment Arm (19) and the Lower Pulley Mount (11) to the Main Upright using the two M10*105 bolts (100) and the M10*110 bolt (101). The slotted holes in the Calf Raise Block Attachment Arm and Calf Raise Block are to allow up and down adjustment to ensure the gym is level.
- E) Tighten the hardware now by starting with bolt 93 (arrow A). Then tighten the Calf Block Attachment Arm (19) to the Main Upright (2). Then tighten the Calf Raise Block (32) to the Calf Raise Block Attachment Arm (19). Tighten all the remaining hardware in Steps A-D at this time.

STEP 3

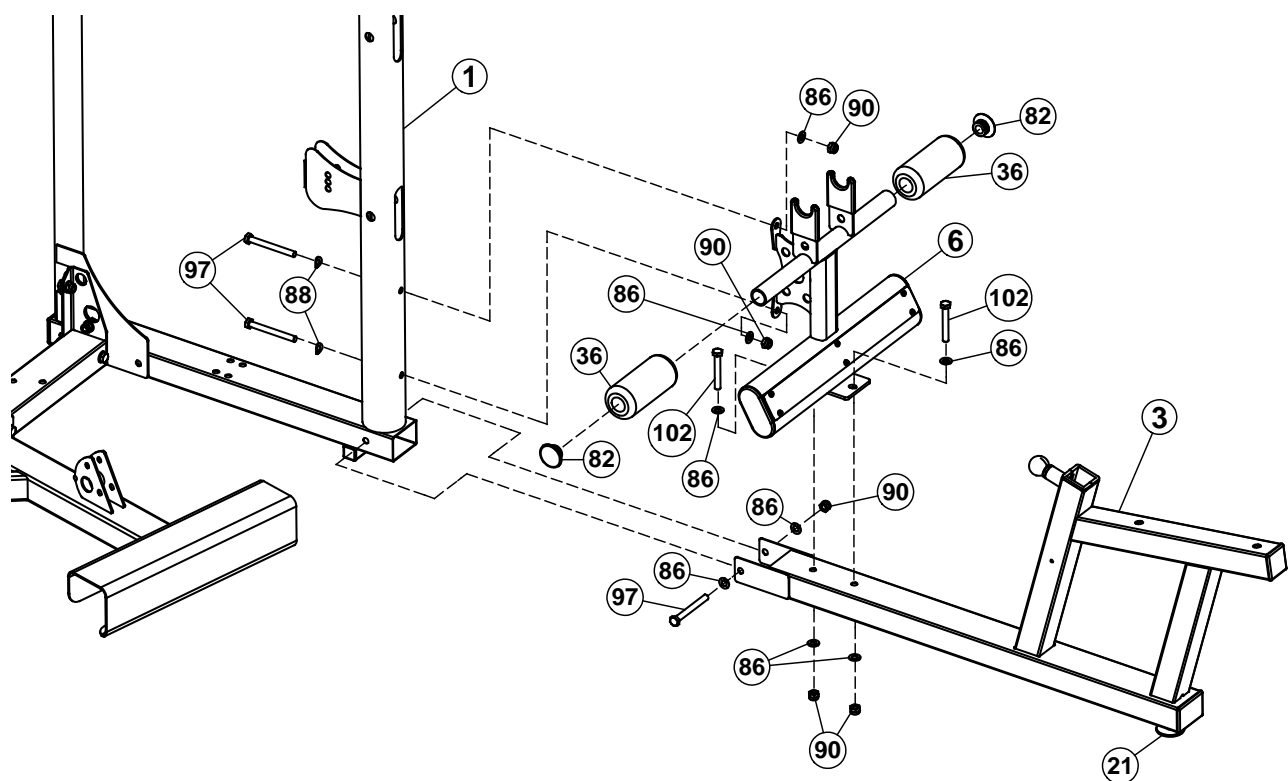

- A) Attach the Foot Rest Assembly (6) to the Lat Seat Frame (3) using the two M10*70 bolts (102).
- B) Attach the Lat Seat Frame (3) to the Main Frame (1) using one M10*95 bolt (97).
- C) Attach the Foot Rest Assembly to the Main Frame using the two M10*95 bolts (97) with the Curved Washers (88) placed against the round tube upright on the Main Frame.
- D) Adjust the Adjustable Stop (21) until it contacts the floor and tighten the Jam Nut.
- E) Slide the two Small Covered Foam Rollers (36) onto the Foot Rest and secure with the two black plastic End Caps (82).

Tighten all the hardware in Steps A-D at this time.

STEP 4

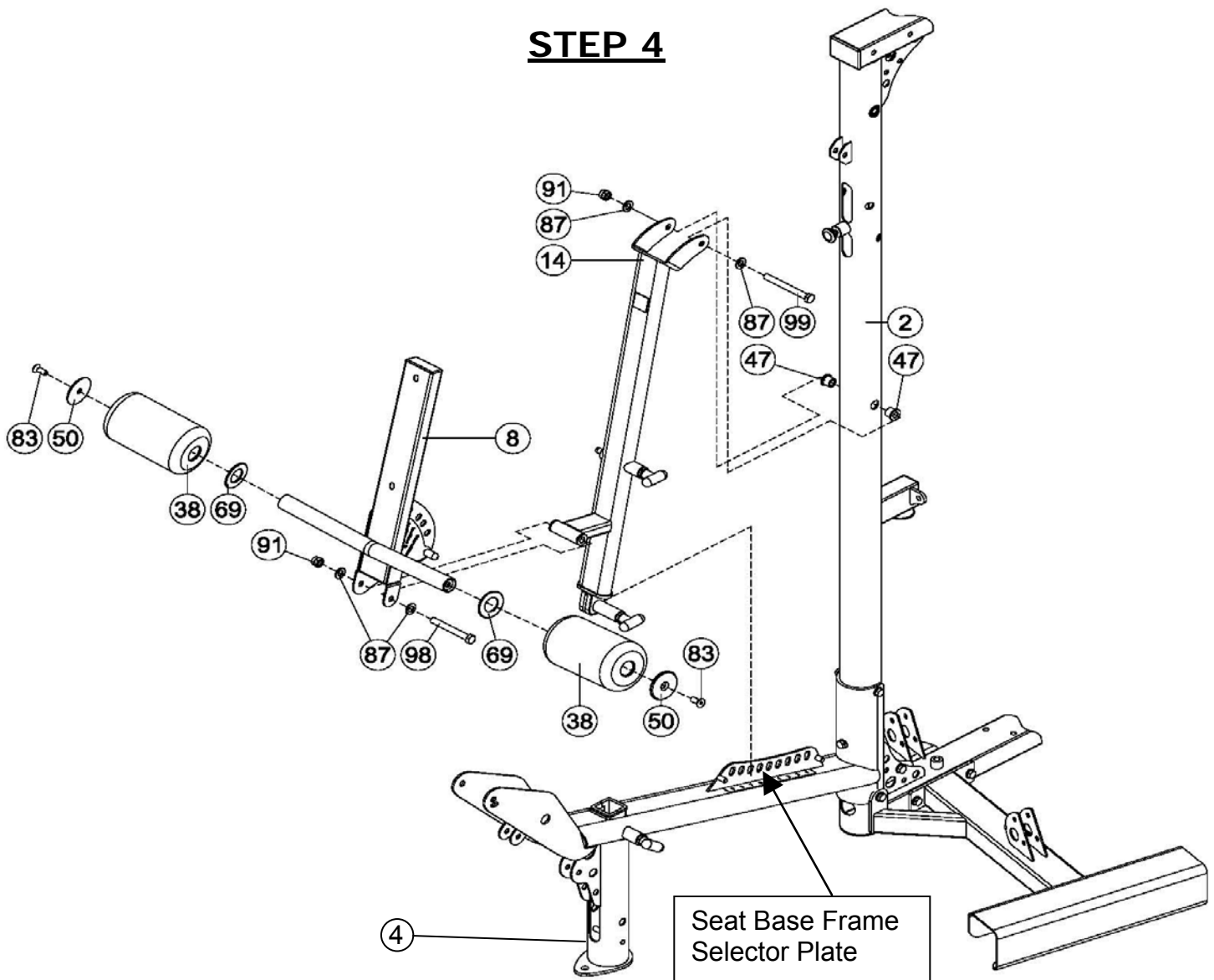

- A) Attach the bottom of the Back Pad Support Frame (14) to the Selector Plate on the Seat Base Frame (4).
- B) Attach the Back Pad Support Frame (14) to the Main Upright (2) using the M12*110 bolt (99). Tighten this bolt now but ensure that the Back Pad Support Frame can move easily.
- C) Attach the Back Pad Mount (8) to the Back Pad Support Frame (14) using the M12*95 bolt (98). Tighten this bolt now but ensure that the Back Pad Mount (8) moves easily.
- D) Install the Large Covered Foam Rollers (38) onto the Back Pad Mount. Ensure that the Large Plastic Washers (69) are placed on the Foam Roller tube first then the pad (38), Aluminum End Cap (50) and then secure this with the M10*25 flat head screws (83). Tighten now.

STEP 5

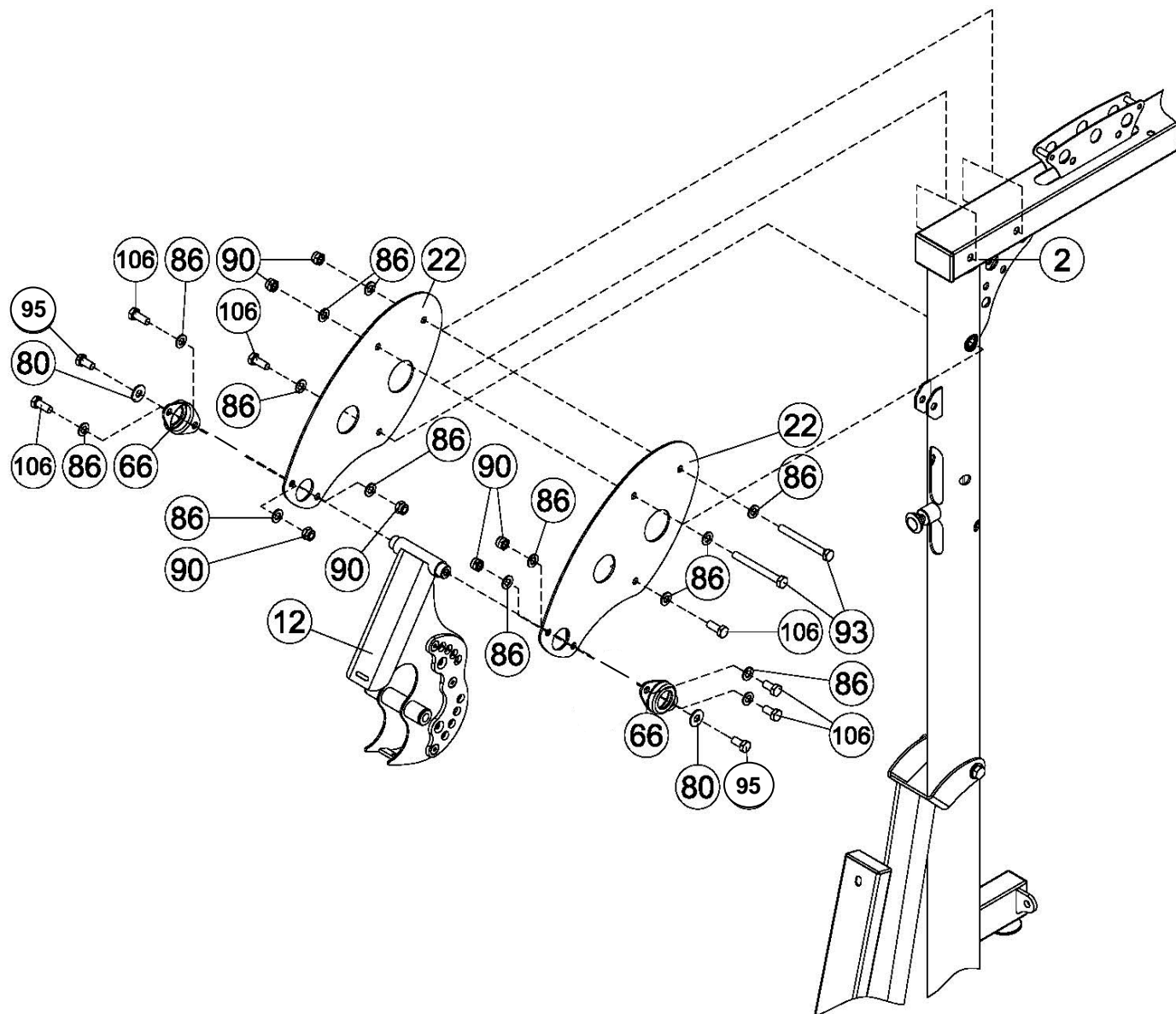

- A) Attach the Top Beam Plates (22) to the Main Upright (2) using the two M10*100 bolts (93) and the smaller M10*20 bolts (106). Only screw in the smaller M10*20 bolts by a couple of threads to allow the Top Beam Plates to move when inserting the Press Arm Mount (12).
- B) Carefully hang the Press Arm Mount (12) from the Top Beam Plates.
- C) Slide the Press Arm Bearing Assemblies (66) onto the shaft of the Press Arm Mount and attach to the Top Beam Plates using the four M10*20 bolts (106) with the eight smaller M10 washers (86).
- D) Install the two M10*20 button head bolts (95) with the large M10 washers (80) to the center of the Press Arm Bearing Assemblies.

STEP 6

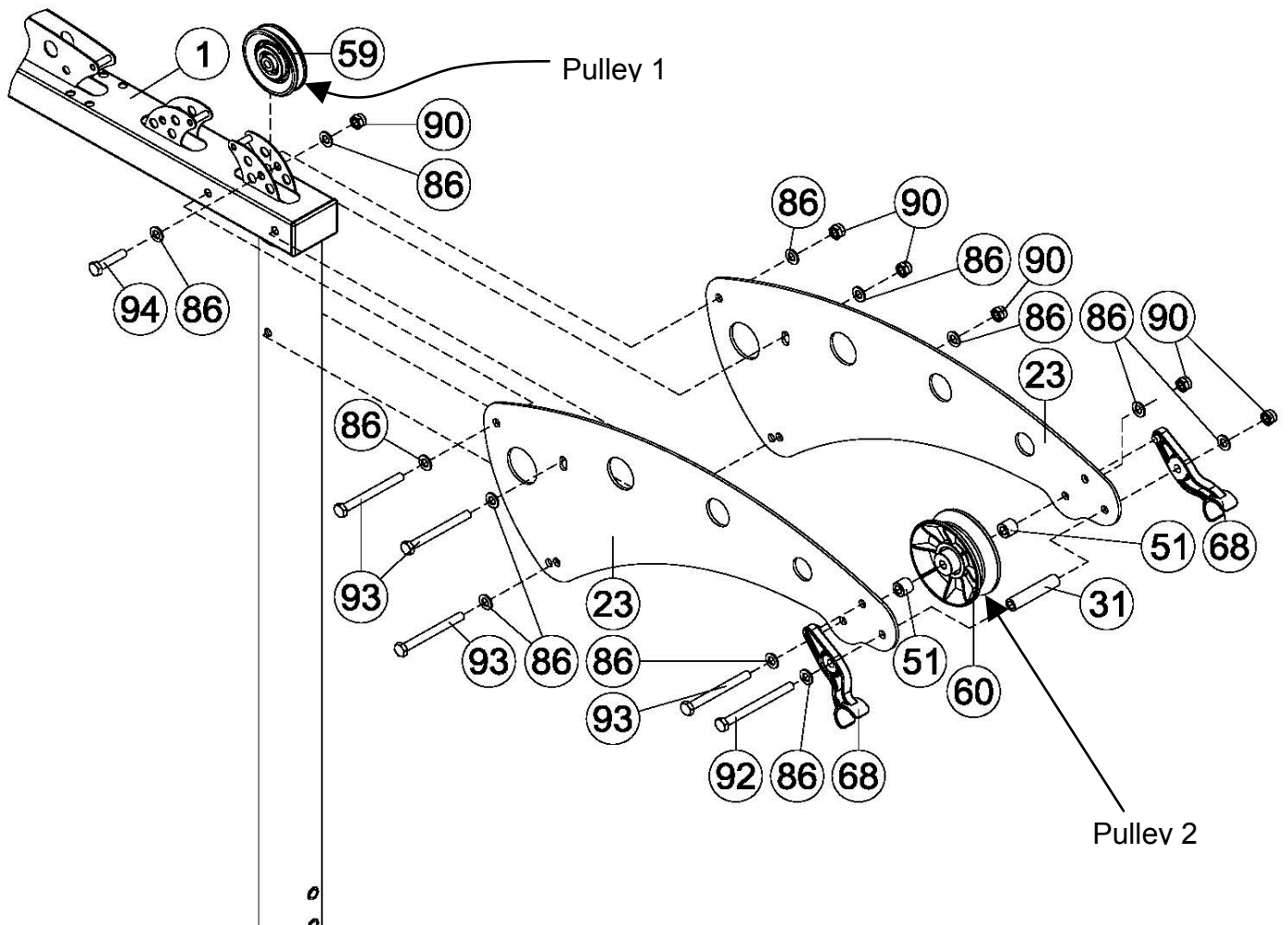

- A) Install the 3.5" Pulley 1 (59) at the top of the Main Frame (1) using the M10*45 bolt (94). Tighten this bolt now.
- B) Install the Top Beam Plates (23), with the Inspire logo to the outside, to the Main Frame using three of the M10*100 bolts (93). The lower bolt should be inserted into the upper hole on the bottom of the Top Beam Plates. (The bottom hole is used for taller customers who need more height to the Lat Bar.)
- C) Install the 4.5" Wide Pulley 2 (60) and 5/8" Barrel Spacers (51) to the Top Beam Plates using the last M10*100 bolt.
- D) Install the Lat Bar Holders (68) with the 3" long Spacer Tube (31) to the Top Beam Plates using the M10*115 bolt (92). The plastic nub on the end of the Lat Bar Holder will fit into the top front hole in the Top Beam Plates. Tighten all the hardware in Steps 6 B through D now.

STEP 7

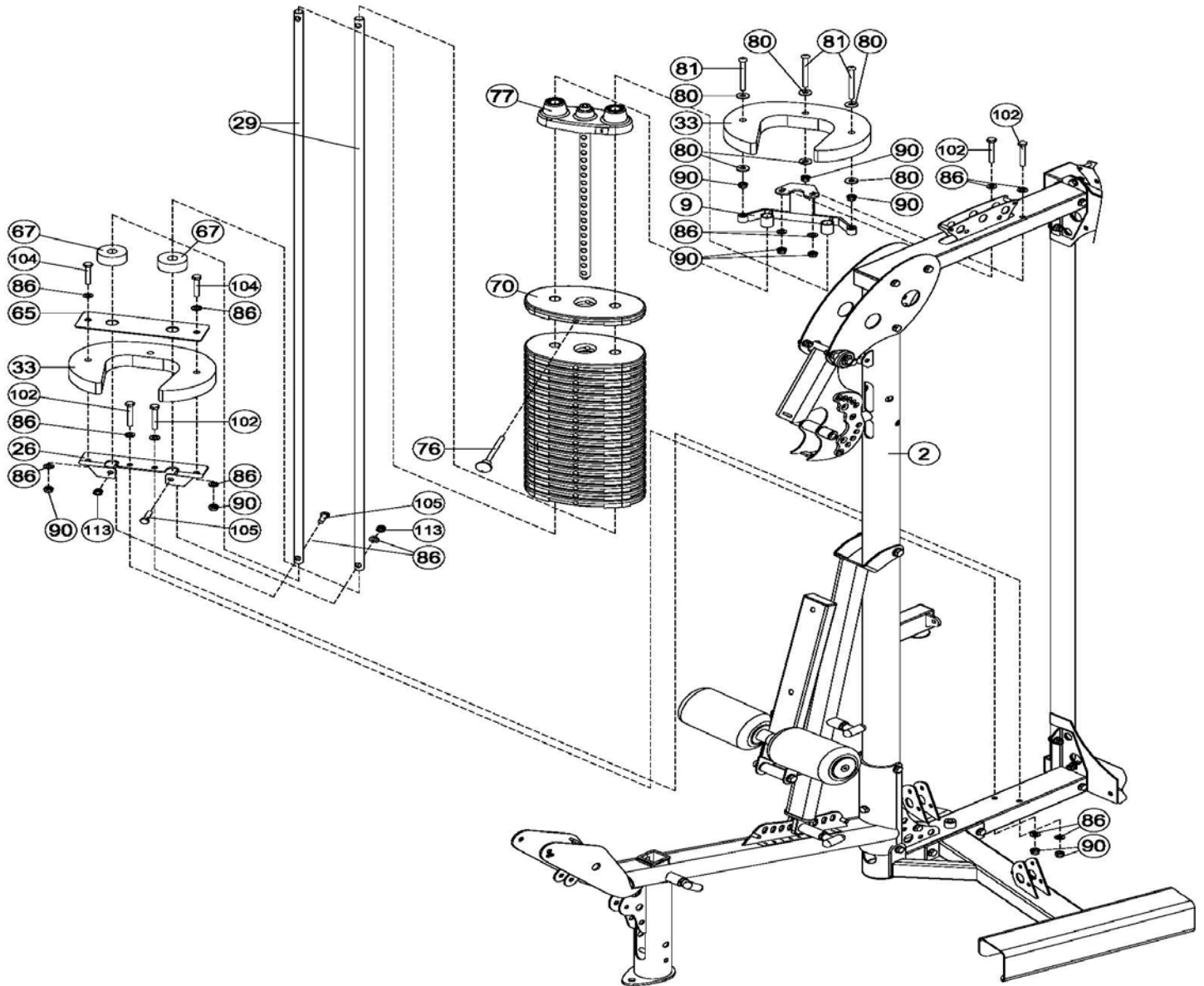

- A) Begin by placing the Lower Guide Rod Mount (26) on the Main Upright (2) as shown with the flanges for bolt 105 towards the front of the gym. Attach the mount using two M10*70 bolts (102). Tighten the bolts now.
- B) Attach the Guide Rods (29) to the Lower Guide Rod Mount using two M10*35 bolts (105). Tighten the bolts now. Do not allow the Guide Rods to bend the mounting bracket while performing the next steps.
- C) Place the Shroud Plate (33) and the Guide Rod Spacer Plate (65) on top of the mount and attach with two M10*60 bolts (104). Do not tighten now.
- D) Slide the Rubber Donuts (67) and 20 Weight Plates (70) onto the Guide Rods.
- E) Slide the Top Weight/Selector Stem (77) onto the Guide Rods.
- F) Using the 6# Allen wrench, attach the Upper Shroud Mount Bracket (9) to the other Shroud Plate. Turn the bolts only about two turns each until the bracket is fully seated to the plate. The bolts will bind if turned more than a couple of turns sequentially.
- G) Now place the whole Upper Shroud Mount Assembly on the Guide Rods and bolt it to the top of the Main Upright using two of the M10*70 bolts (102). Tighten this hardware, and Step C hardware, now. Ensure that all the hardware is tight.
- H) Insert the weight stack pin into the weight plates.

STEP 8

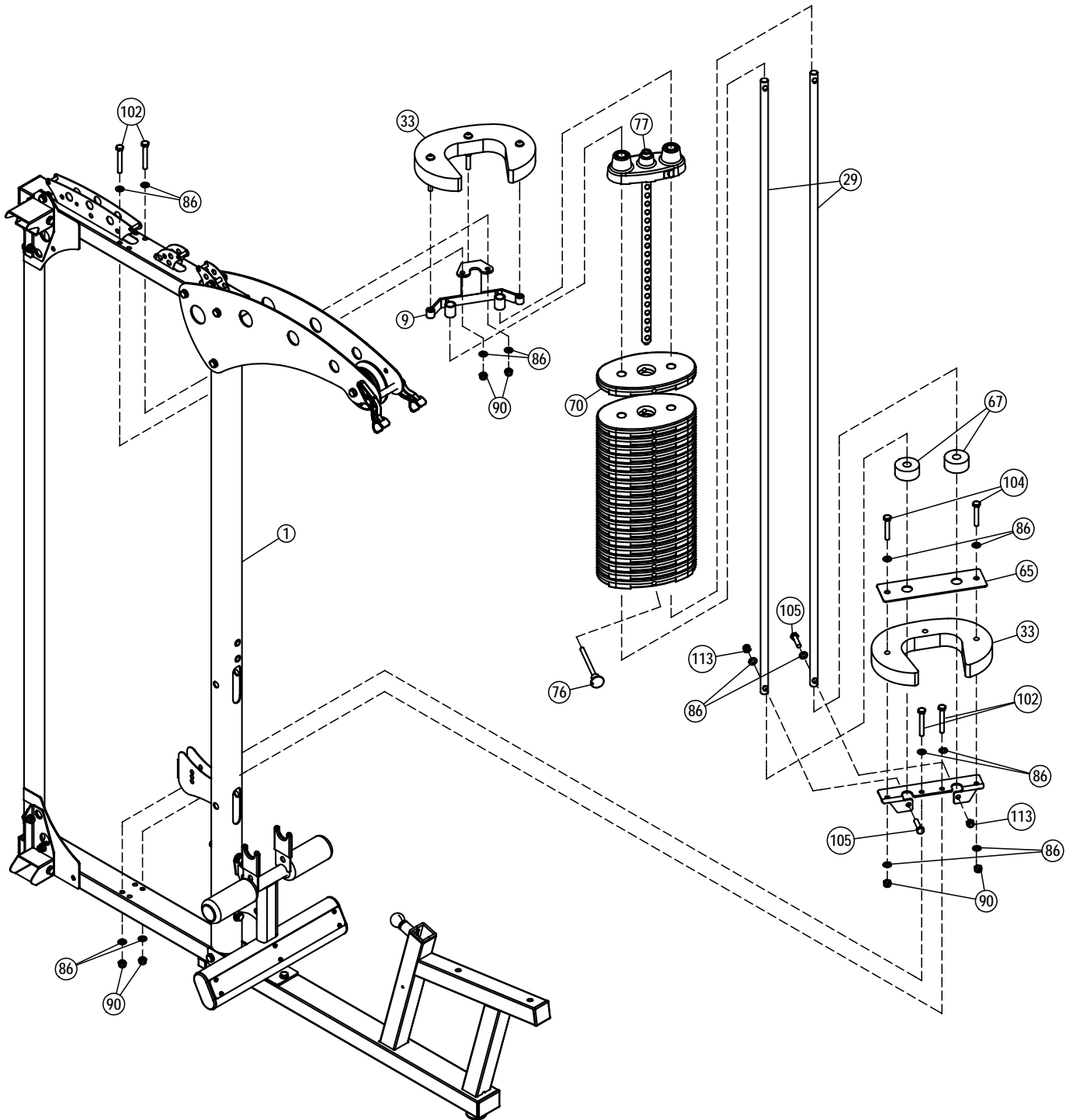

Repeat the Step 7 instructions to complete Step 8 with the weight stack angled towards the center of the gym as shown. If installing the LP2 Leg Press, then angle the weight stack towards the outside of the gym.

STEP 9

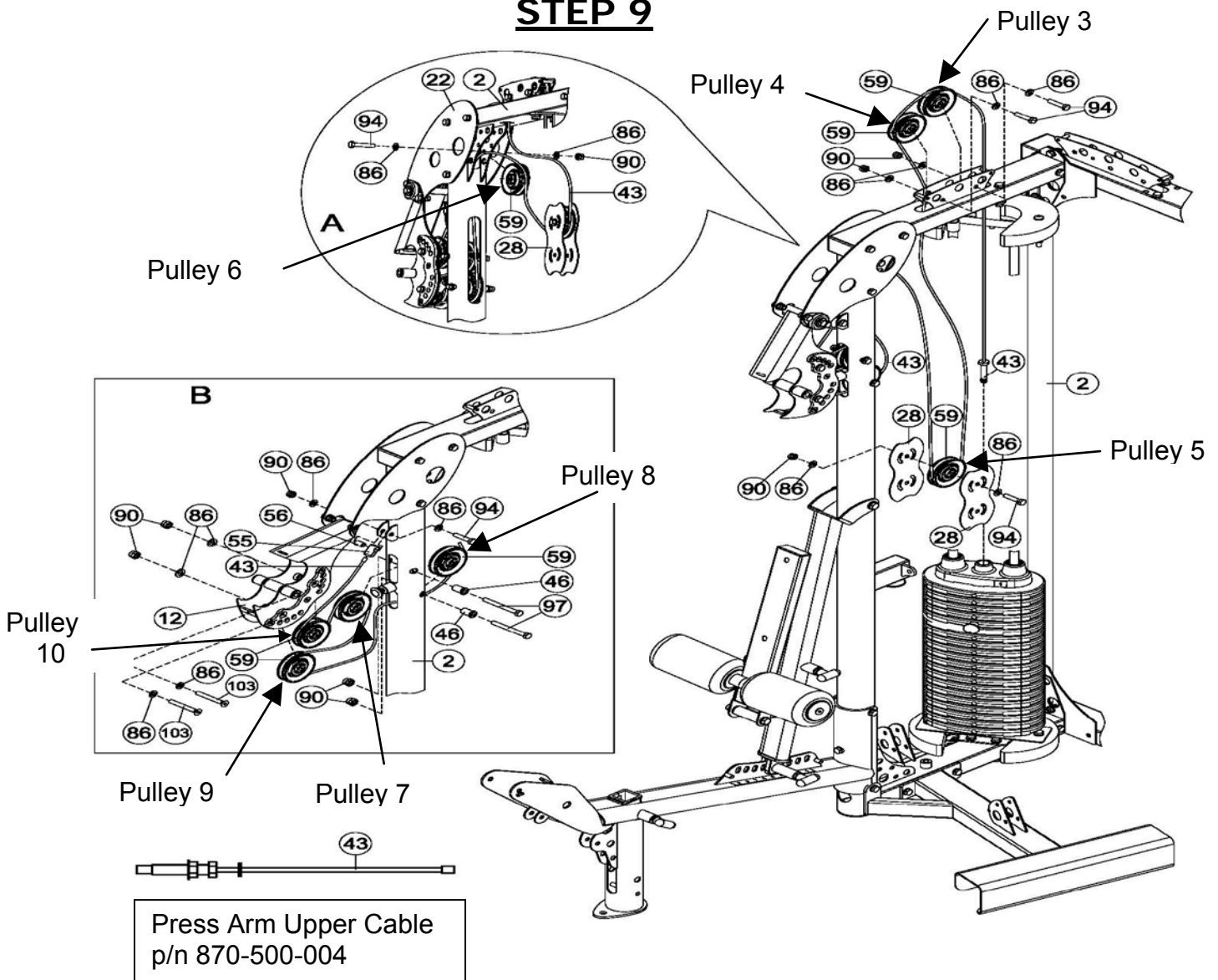

Attach pulleys 3 and 4 to the Main Upright (2) as shown with the M10*45 bolts (94). Pulley 5 is assembled with the Floating Pulley Plates (28) and M10*45 bolts as shown. Pulley 6 is assembled in the corner of the Main Upright between the Top Beam Plates (22) with the M10*45 bolt as shown. Pulleys 7 and 8 are installed inside the 3" round tube of the Main Upright. Pulley 7 is above Pulley 8 and they are installed with the 1" Step Spacers (46) as shown on both sides of the tube. Pulleys 9 and 10 are attached to the Press Arm Mount (12) as shown with the M10*70 bolts (103). Tighten all pulley hardware now.

To route the Upper Cable (43), start by laying it out on the floor to completely unwind it. Then fully insert the threaded end into the Top Plate of the Weight Stack. With the other end, run the cable up and over Pulleys 3 and 4 and then down and around Pulley 5 before going back up to Pulley 6 in the corner of the gym. After routing over Pulley 6 run the cable down through the 3" tube and around the bottom of Pulley 8 then to the bottom of Pulley 9 in the Press Arm Mount. Continue back through the 3" round tube to run the cable around the bottom of Pulley 7. Head back out of the 3" round tube to the bottom of Pulley 10 in the Press Arm Mount. Go around Pulley 10 and secure the cable end to the bracket at the top of the 3" round tube as shown using the M10*45 bolt and the Cable End (55) with Bushing (56) and tighten the hardware.

STEP 10

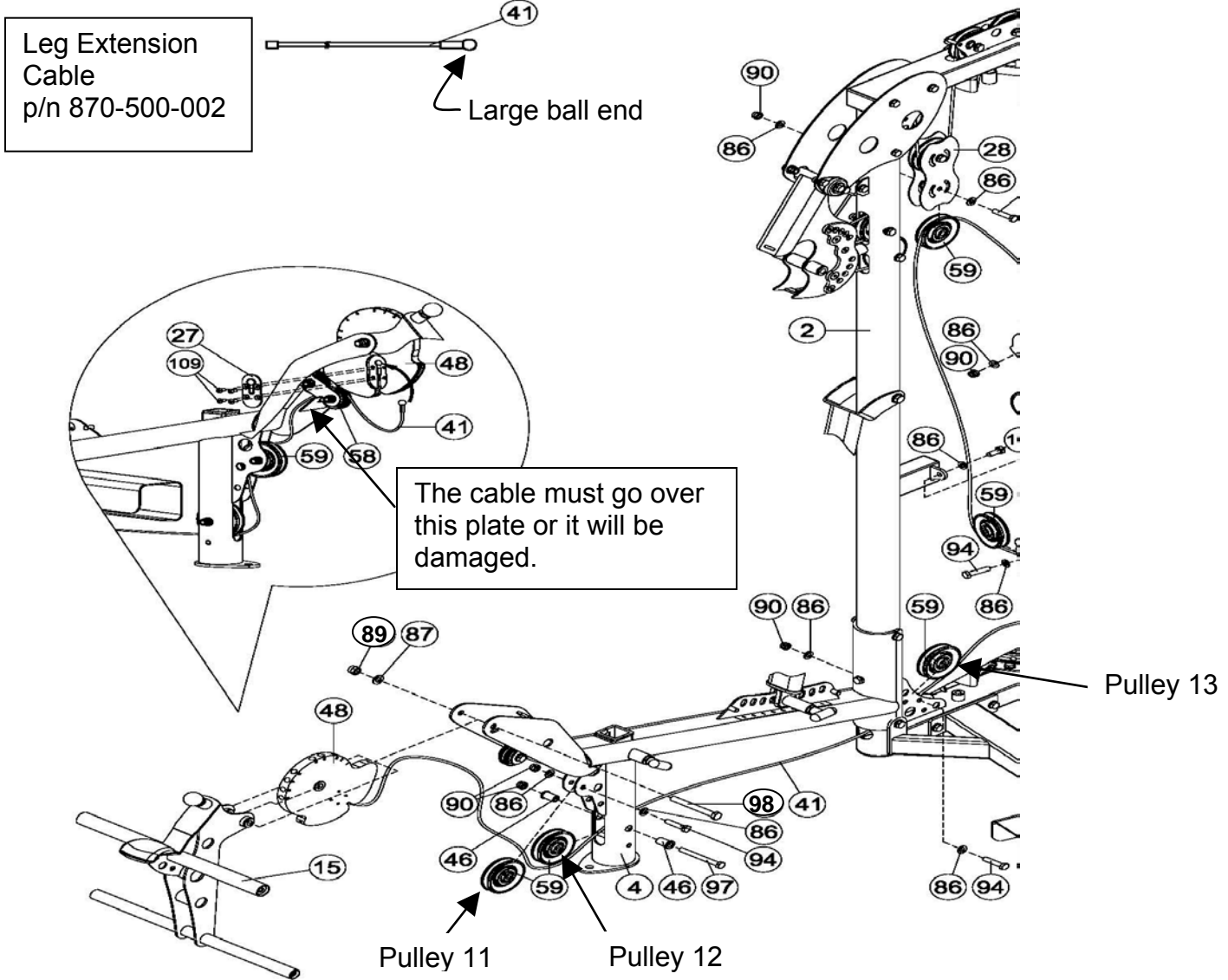

- A) Install Pulley 11 and 13 with the M10* 45 bolts (94) and Pulley 12 with the M10*95 bolt (97) and two 1" Step Spacers (46) as shown in the drawing. Tighten the hardware at this time.
- B) On the Leg Extension Cam Assembly (48), remove the four flat head screws (109) and the chrome Cam Plate (27). Next insert the large ball end of the cable into the recessed area and reinstall the chrome Cam Plate with the four screws. Tighten the screws. Then feed the other cable end between the two small pulleys (58), over the metal plate and down to Pulley 11 as shown in the expanded drawing. Run the cable behind Pulley 11 then down and under Pulley 12 and then to the back of the gym. Be sure the cable goes between Pulley 12 and the cable retainer rod welded inside the tube. You will finish routing it after Step C.
- C) Now insert the Leg Extension Cam Assembly (48) into the Leg Extension Assembly (15) with the selector number 5 at the top. Now while holding them together, place them between the two plates of the Seat Base Frame (4) and assemble using the M12*95 bolt (98), flat washer (87), and thin locknut (89). Tighten this bolt but do not over tighten as the Leg Extension must be able to rotate freely.
- D) Now continue routing the cable by running it through the bottom of the Main Upright (2) and under Pulley 13. You will finish with this cable in Step 10B.

STEP 12

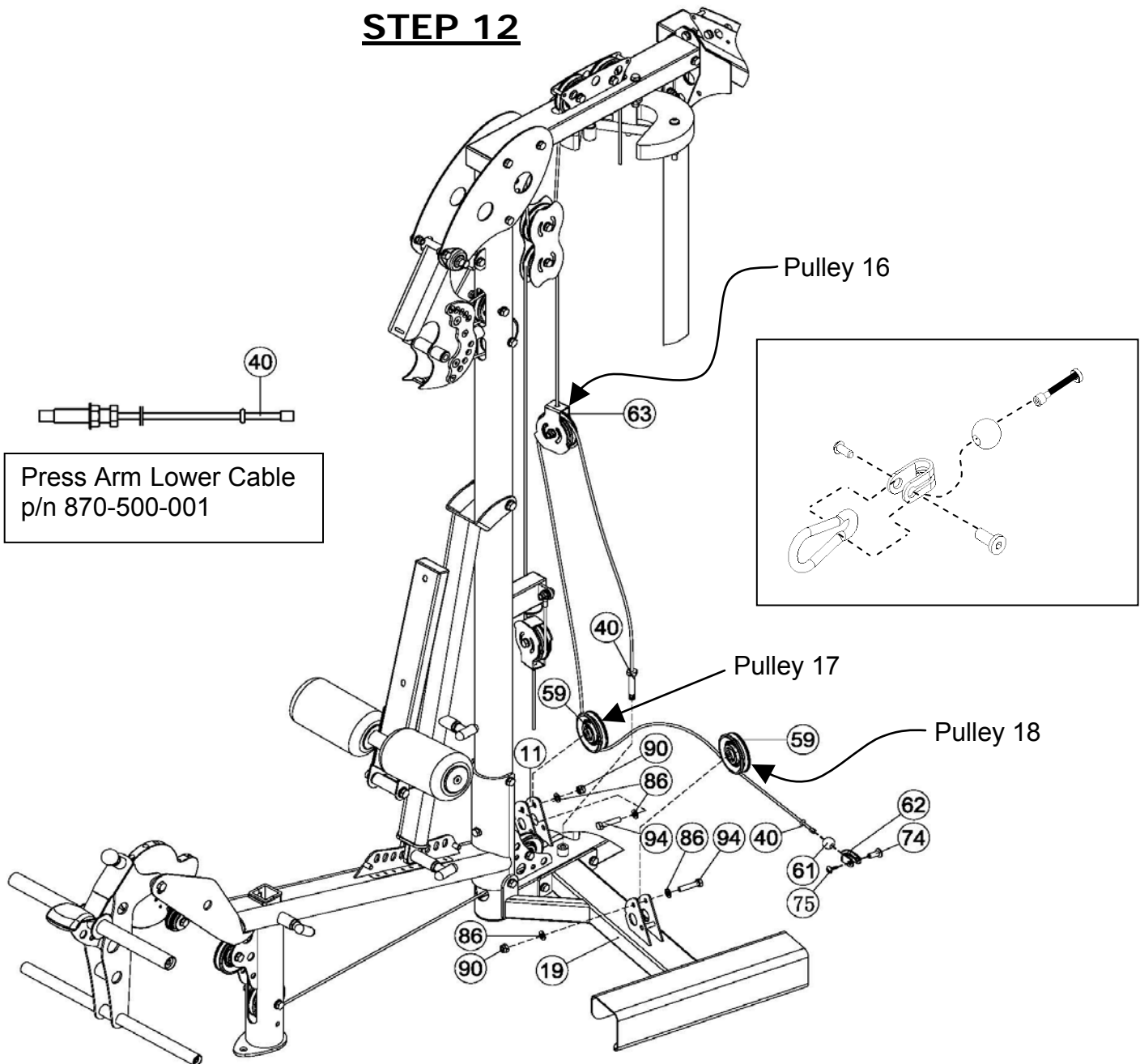

- A) Install Pulleys 17 and 18 with M10*45 bolts (94) and tighten the hardware.
- B) Begin routing the Lower Cable (40) by screwing the threaded end half way into the frame, near Pulley 17, as shown and tighten the Jam Nut. Then route it up and around Pulley 16, down around the bottom of Pulley 17 and then under Pulley 18.
- C) Remove the hardware from the "U" Bracket (62). Assemble the cable end by sliding one black Cable Ball (61) on the end of the cable just up to the little Rubber Donut then slide the cable end into the side of the "U" Bracket. Bolt the Spring Clip to the "U" Bracket with the hardware.
Retighten the "U" Bracket hardware now. Slide the Rubber Donut and Cable Ball tightly against the "U" Bracket.

STEP 13

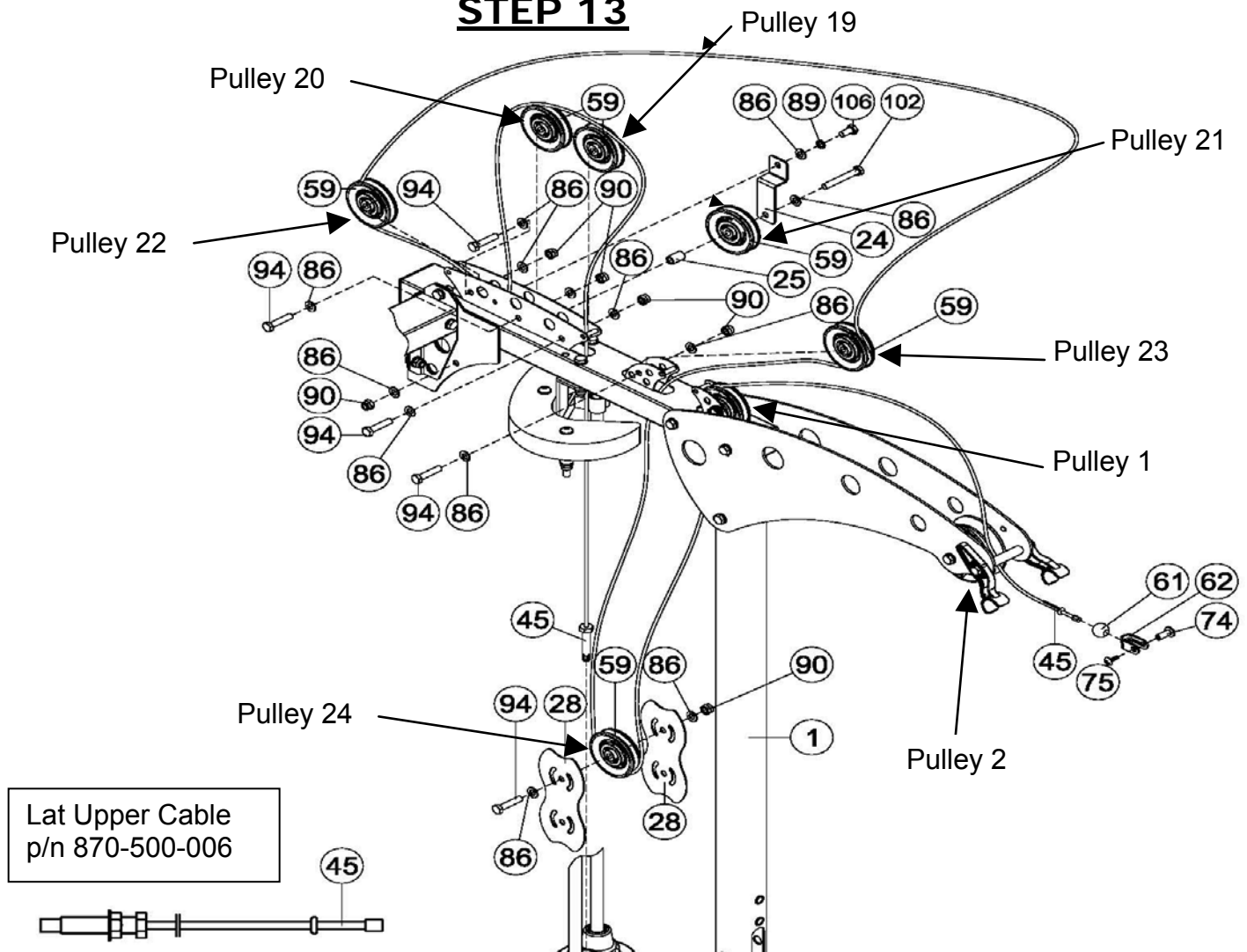

- A) Install the Pulley Bracket (24) to the back side of the gym under Pulley 22 with M10*20 bolt (106). This bolt is installed in the threaded insert located below Pulley 22 on the back side.
- B) Install Pulley 19, 20, 22 and 23 at the top of the Main Frame (1) with the M10*45 bolts (94). Pulley 21 is installed directly below Pulley 22 but on the back side of the gym. It is attached to Pulley Bracket (24) and the gym with the M10*70 bolt (102) and the 1" Barrel Spacer (25) between the pulley and the Main Frame as shown at the top of the picture.
- C) To route the Lat Upper Cable (45), first unwind it by stretching it out on the floor. Then fully screw the threaded end into the Top Plate of the weight stack and tighten the Jam Nut. Route the cable up and around both Pulley 19 and 20 as shown. Continue by routing the cable down and around Pulley 21 then up and around Pulley 22. From there run the cable over the top of the gym, over Pulleys 20 and 19, then down and around Pulley 23 before running it down to the back side of Pulley 24. Pulley 24 is assembled with two Floating Pulley Plates (28) and the M10*45 bolt. Run the cable around Pulley 24 and from there run the cable up and over Pulley 1 and 2. Make sure that the cable is routed between Pulley 2 and the 3" spacer or the cable will be damaged. Finish the cable end the same way it was finished in Step 12.

Tighten the hardware for Pulleys 19, 20, 21, 22, 23 and 24 at this time. Also ensure that the hardware for the Pulley Bracket (24) is tight at the top of the gym.

STEP 14

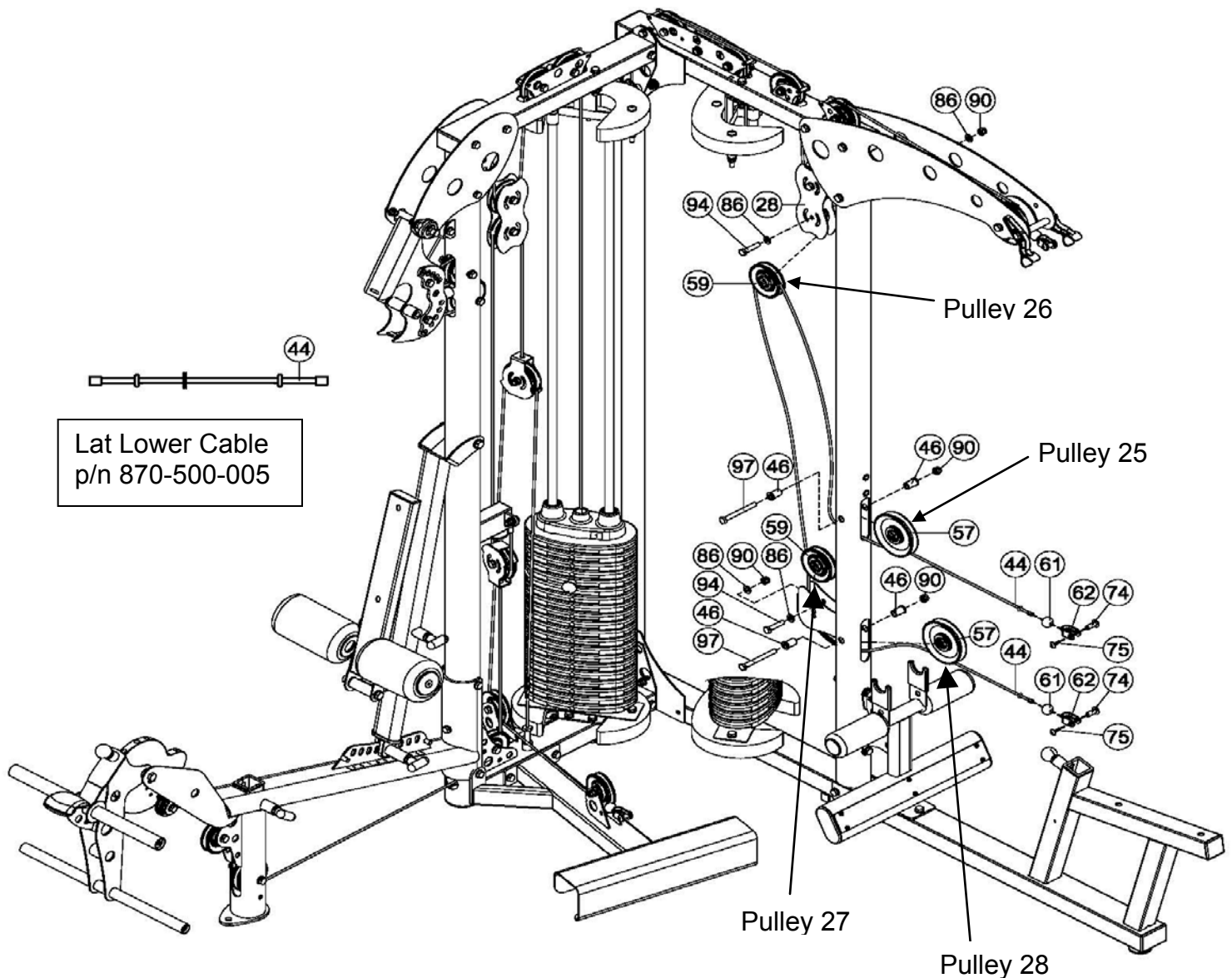

- A) Install 4.5" Pulleys 25 and 28 (57) in the 3" round tube of the Main Frame as shown with the 1" Step Spacers (46) and M10*95 bolts (97). Install Pulley 26 in the Floating Pulley Plates with M10*45 bolt (94). Install Pulley 27 in the upper hole in the bracket on the back side of the 3" round tube of the Main Frame with M10*45 bolt (94).
- B) To route the Lat Lower Cable (44), first unwind it by stretching it out on the floor. Assemble the cable end as in Step 12. This will help to keep the cable from following through the gym as it is routed. Begin routing with the other end of the cable by running it under Pulley 25, up and around the front of Pulley 26 in the Pulley Brackets, down to the backside of Pulley 27 then under Pulley 28 and out like shown in the diagram.
- C) Finish the last Cable Ends as Step as above.

Make sure that the hardware for Pulleys 25, 26, 27 and 28 are properly tightened.

STEP 15

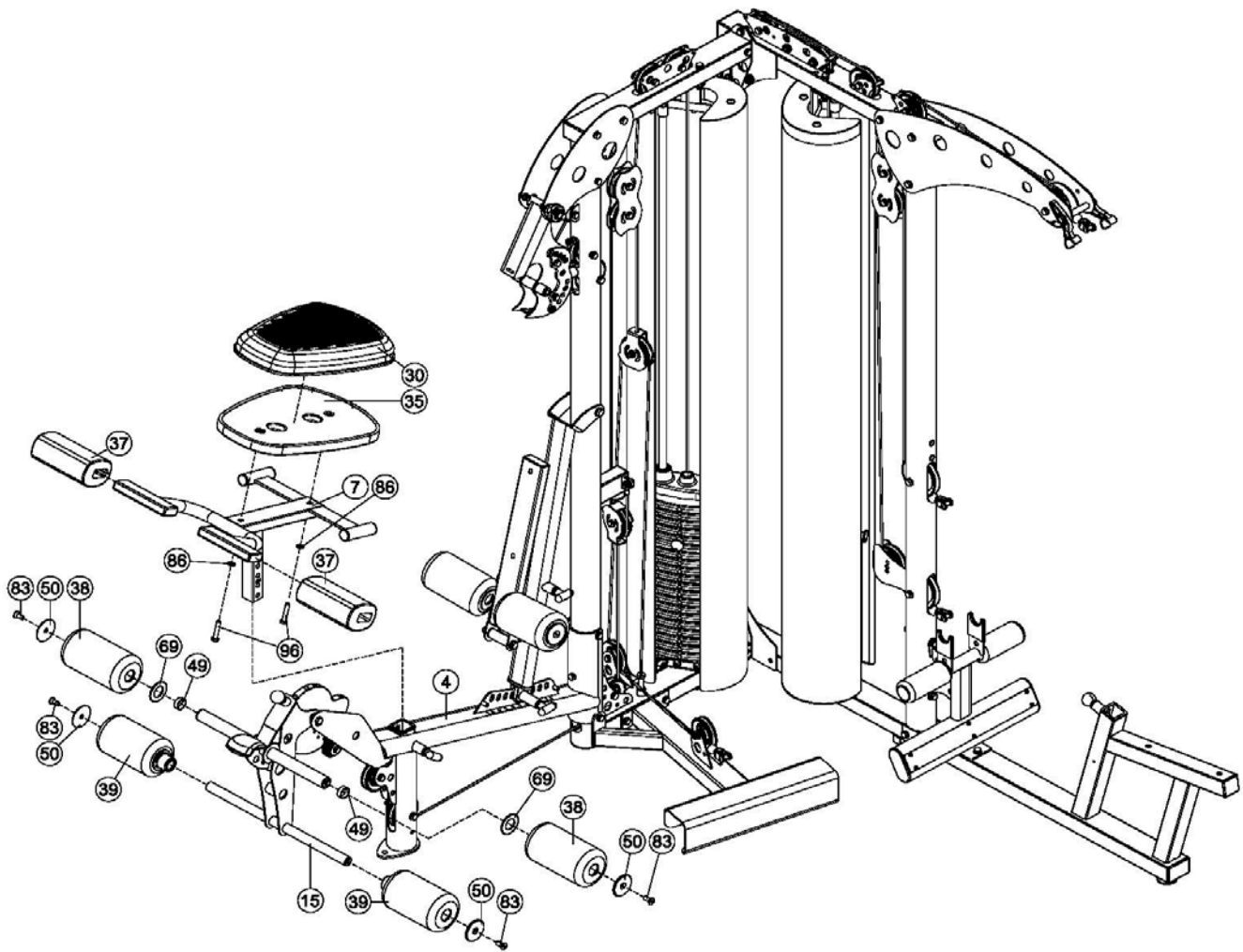

- A) Insert the Seat Stem Assembly (7) into the Seat Base Frame (4) as shown. Pull the pop pin out to allow the seat to lower to a normal height. Then attach the Seat Base Assembly (35) to the Seat Stem Assembly using the two M10*50 bolts (96) and two M10 Washers (86). Tighten these bolts now but do not over tighten them or damage can occur. Now install the Orthopedic Pad (30) on the Seat Base by working the edge of the pad into the groove of the Seat Base on all sides. Do not use sharp objects during installation. Finally slide the Thigh Pads (37) onto the Seat Stem as shown and secure with Velcro.
- B) Install the Large Covered Foam Rollers (39) with the plastic inserts in them onto the lower arms of the Leg Extension Assembly (15) as shown. Ensure that the Tube inserts are facing inwards. Secure the Rollers with the Aluminum Endcaps (50) and the M10* Flat Head Screws (83). Tighten the screws at this time with the 6# Allen Wrench supplied. Next install the other Large Covered Foam Rollers (38) on to the upper arms of the Leg Extension Assembly by first sliding on the plastic Spacer Tubes (49), large plastic Washers (69) and Rollers (38) on to the arms and secure with the Aluminum End Caps (50) and M10 Flat Head Screws (83). Tighten the screws at this time with the 6#Allen Wrench.

STEP 16

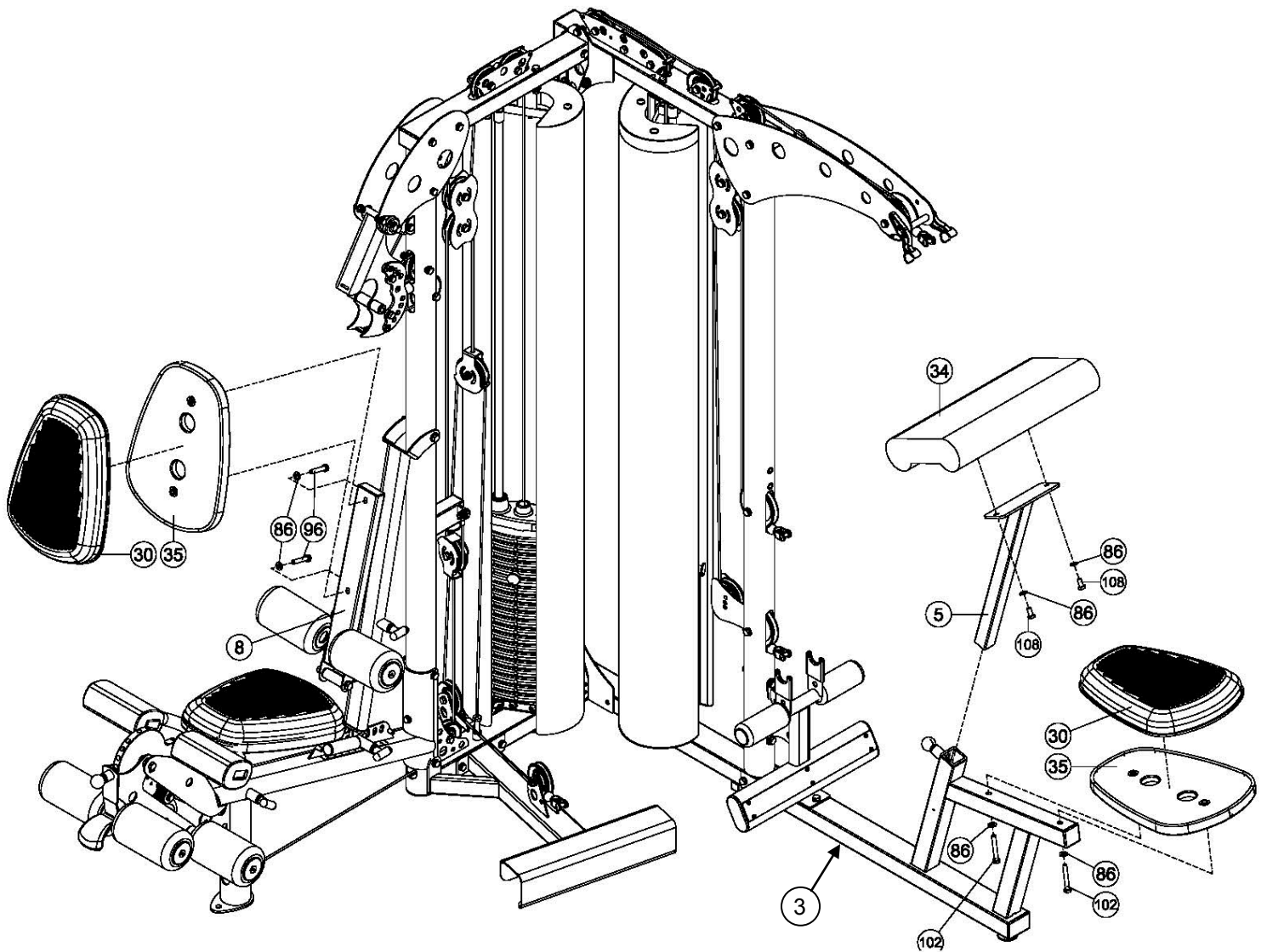

- A) Attach the Seat Base Assembly (35) to the Back Pad Mount (8) using two M10*50 bolts (96) and two M10 Washers (86). Tighten these bolts now but do not over tighten them or damage can occur. Now install the Orthopedic Pad (30) on the Seat Base by working the edge of the pad into the groove of the Seat Base on all sides. Do not use sharp objects during installation.
- B) Attach the Seat Base Assembly (35) to the Seat Frame (3) using the two M10*70 bolts (102) and two M10 Washers (86). Tighten these bolts but do not over tighten or damage might occur. Now install the Orthopedic Pad as in step A.
- C) Attach the Preacher Curl Pad (34) to the Preacher Curl Stem (5) using the two M10*25 bolts (108) and two M10 Washers (86) as shown. Tighten the hardware but do not over tighten.

STEP 17

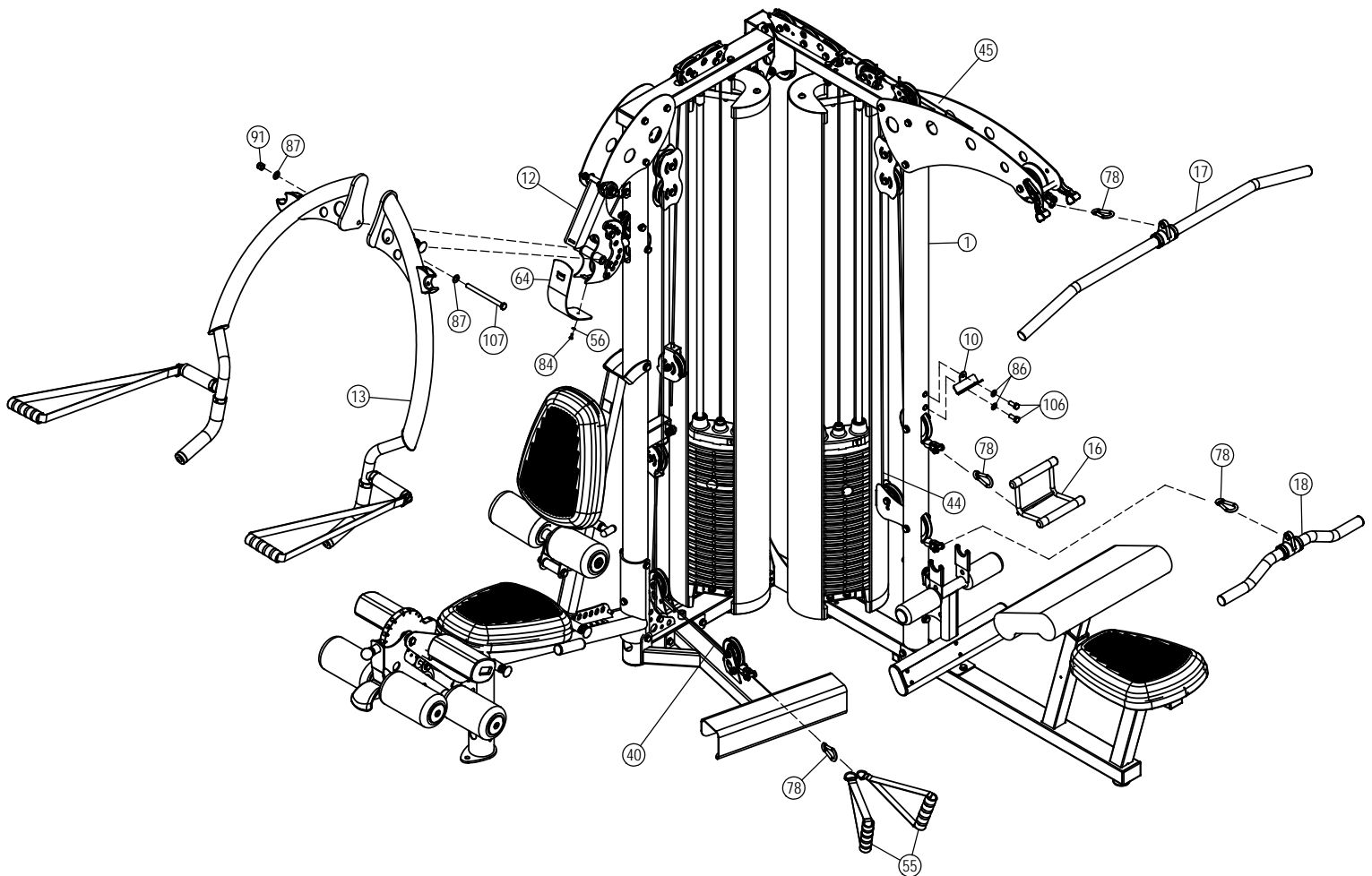

- A) Attach the Press Arm Assembly(13) to the Press Arm Mount (12) using the M12*150 bolt (107) and wrench tighten now but make sure the Press Arm can move freely. Attach the Press Arm Cover Plate (64) to the Press Arm Mount and secure with the M5*12 screw (84) and the M5 washer (56). Tighten the screw now.
- B) Attach the Double "D" Low Row Handle Mount (10) to the Main Frame Lat (1) using M10*20 bolts (106) and M10 Washers (86). Attach the Double "D" Low Row Handle (16) to the upper end of the Lat Lower Cable (44) with the Spring Clip (78).
- C) Attach the Curl Bar (18) to the bottom end of the Lat Lower Cable (44) using one Spring Clip.
- D) Attach two "D" Handle Straps (55) to Press Arm Lower Cable (40) using one Spring Clip.
- E) Attach the Lat Bar (17) to the Lat Upper Cable (45) using one Spring Clip.

STEP 18

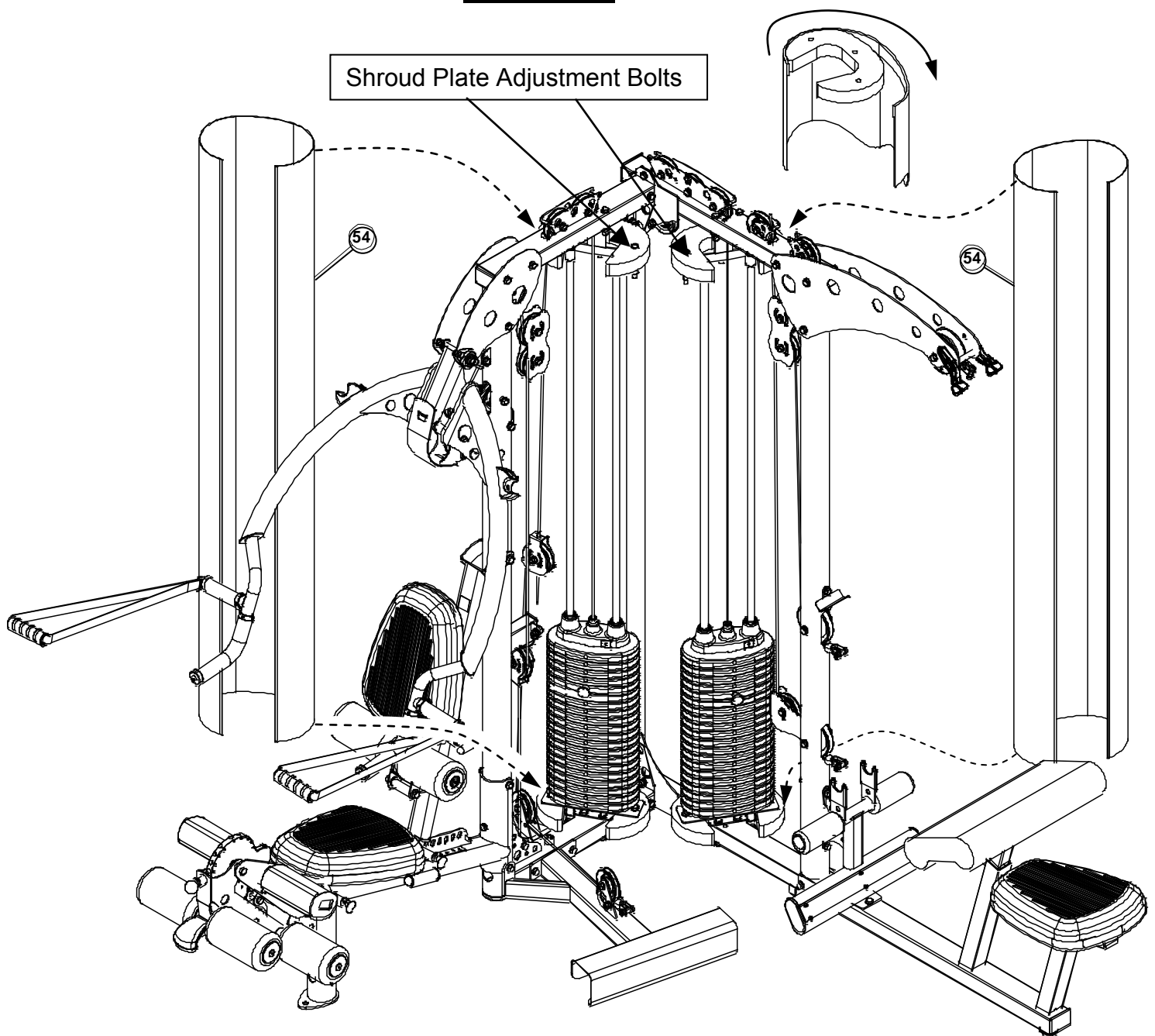

- A) To install the Fabric Shrouds (54), start at the front of the top Shroud Plate (33) and wrap the edge of the fabric shroud around the shroud plate. Pull tight as you wrap and make sure that the Velcro rim on the fabric shroud seals firmly to the Velcro rim on the Shroud Plate. Next do the same for the bottom of the fabric shroud around the bottom shroud plate. Be sure to pull tight as the fabric shroud is wrapped.

If ripples appear on the fabric shroud, undo the top of the shroud and re-wrap, pulling up as the shroud is wrapped. This should give a nice smooth consistency to the shroud. If necessary the shroud can be tightened by adjusting the Shroud Plate Adjustment bolts.

DECAL REFERENCE

INSPIRE

NOTICE				
<i>This INSPIRE product is not intended for commercial use.</i>				
IN HOME MAINTENANCE	Weekly	Months ³	Yearly	Years ²
Inspect; Links, Pull Pins, Snap Locks, Swivels, Weight Stack Pins	X			
Clean; Upholstery	X			
Inspect; Cables and their fittings	X			
Inspect taughtness of all shrouds	X			
Inspect; Accessory Bars and Handles		X		
Inspect; All Decals		X		
Inspect; All nuts and Bolts Tighten if Needed.		X		
Inspect; Anti-Skid Surfaces		X		
Clean & Lubricate; Guide Rods with a Teflon(PTFE) based lubricant (Superlube)		X		
Lubricate; Seat Sleeves and all plastic slides		X		
Clean & Wax; All Glossy Finishes			X	
Replace; Cables, Belts and Connectin Parts.				X



INSPIRE™
 BY HEALTH IN MOTION LLC
 877-738-1729
www.inspirefitness.net
 Serial # 1-05-05-00001

This product is covered by one or more of the following U.S. Patents: 7,722,513; 7,837,600; 7,905,818; 5,330,405; 5,944,641; 5,961,427; and others pending

WARNING

USE ONLY GENUINE INSPIRE REPLACEMENT PARTS. FAILURE TO DO SO WILL VOID WARRANTY AND COULD RESULT IN SERIOUS INJURY. THERE IS A RISK ASSUMED BY INDIVIDUALS WHO USE THIS TYPE OF EQUIPMENT. TO MINIMIZE THE RISK, ALWAYS FOLLOW THESE RULES.

1. READ & UNDERSTAND ALL ENCLOSED INSTRUCTIONS BEFORE USING THIS EQUIPMENT.
2. INSPECT EQUIPMENT BEFORE EACH USE. Replace parts that show any wear or damage. If in doubt about a certain part, DO NOT use the equipment until the part is replaced. Failure to replace worn or damaged parts may result in injury.
3. FOLLOW MAINTENANCE SCHEDULE on the "NOTICE" sticker
4. CONSULT YOUR PHYSICIAN BEFORE STARTING ANY EXERCISE PROGRAM. Warm up properly before exercising. Stop exercising if you feel faint or dizzy.
5. TO PREVENT THE POSSIBILITY OF SERIOUS INJURY, KEEP CLEAR OF ALL MOVING PARTS. DO NOT ATTEMPT TO FREE ANY JAMMED PART BY YOURSELF. Obtain assistance in order to avoid possible injury.
6. Take your time and do not rush exercise. Practice proper breathing, NEVER hold your breath.
7. CHILDREN SHOULD NOT BE ALLOWED TO USE THIS EQUIPMENT. To avoid possible injury, children should be kept at a safe distance when this equipment is in use. Teenagers should not use this equipment without adult supervision.
8. CALL YOUR AUTHORIZED INSPIRE DISTRIBUTOR if you have any questions on the proper use or maintenance of this equipment.

DECAL REFERENCE

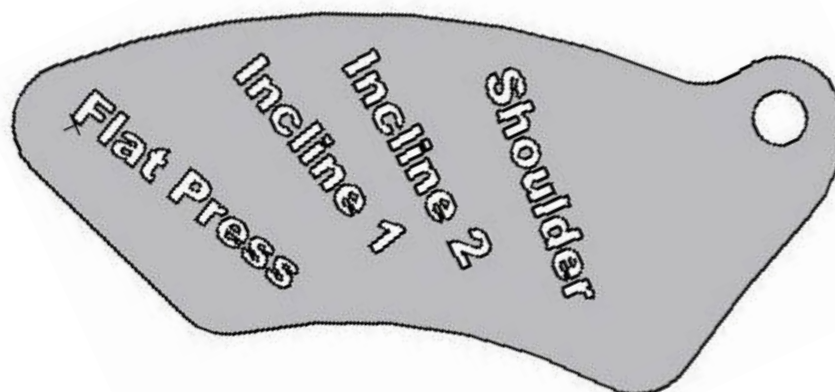
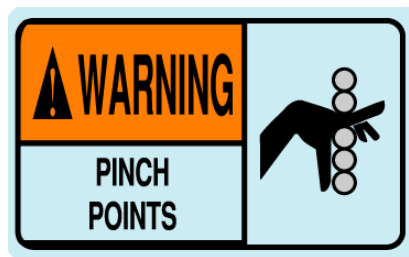
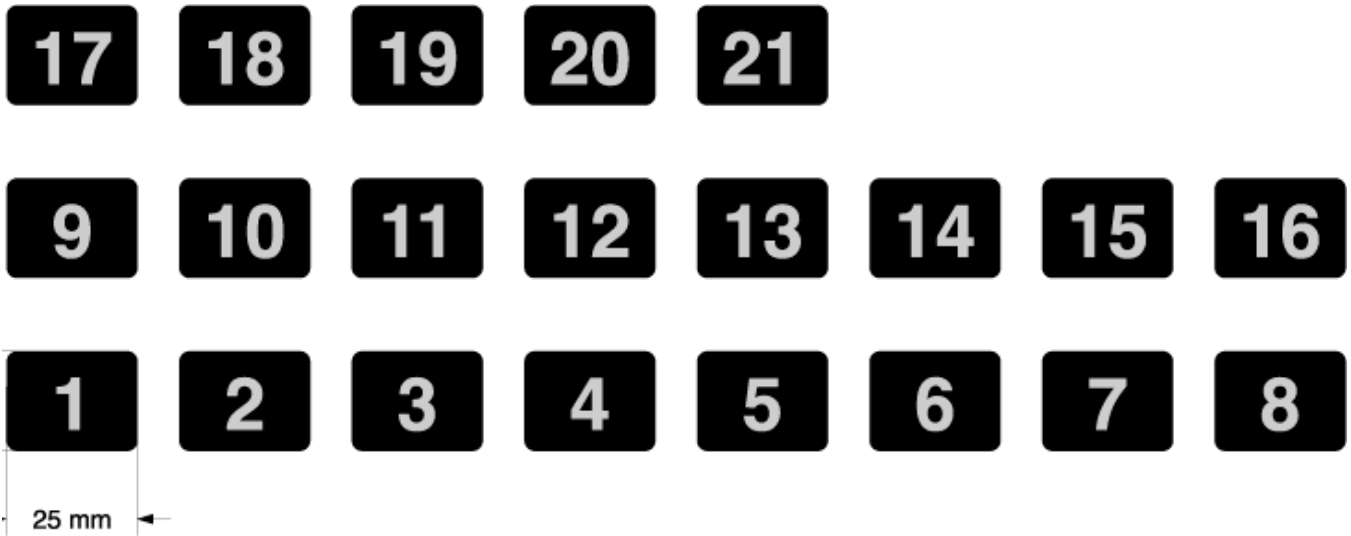

DECAL PLACEMENT

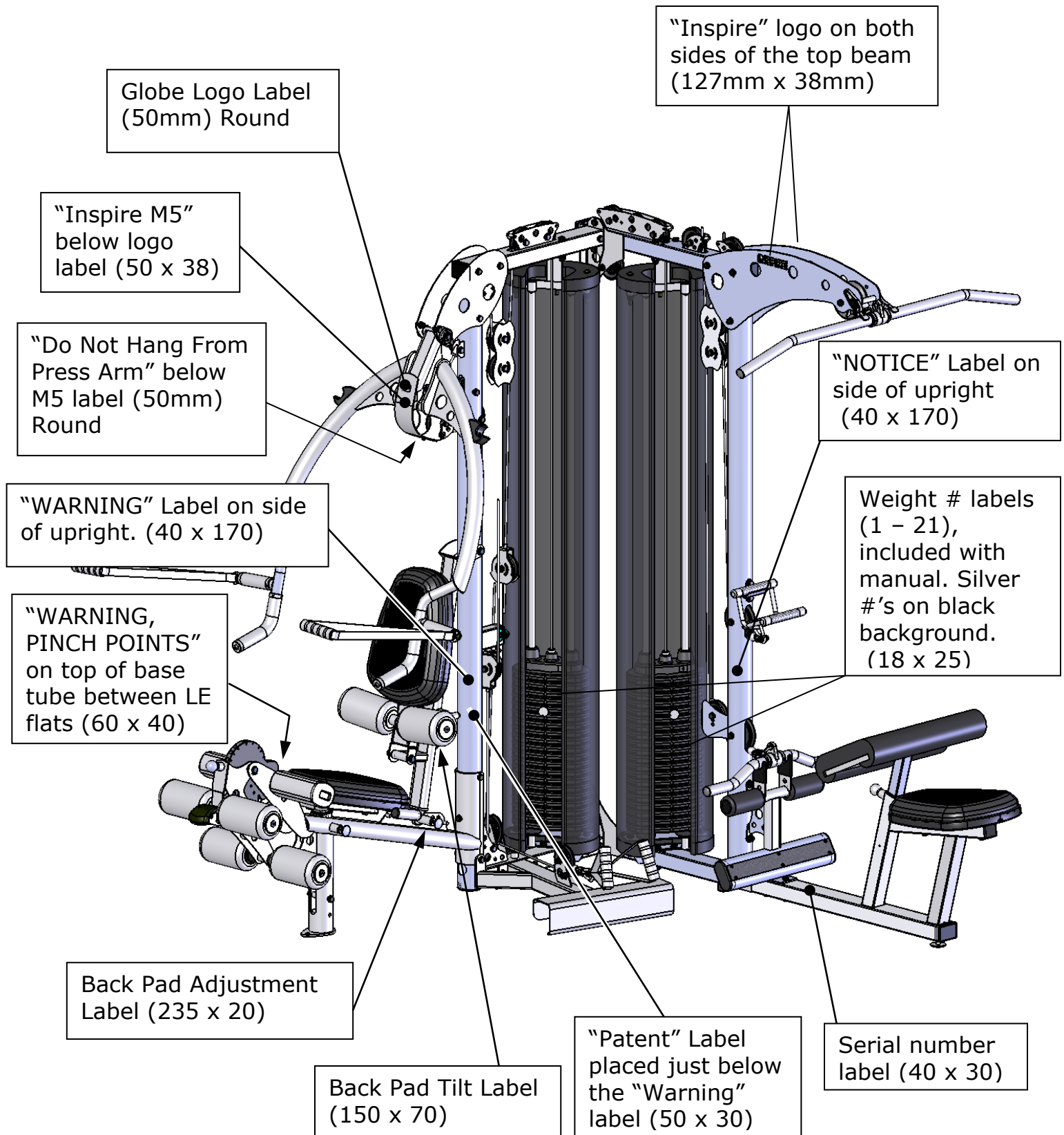

ACCESSORIES

- Exercise Wall Chart
- Revolving Lat Bar
- Revolving EZ Curl Bar
- Double D Low Row Handle
- D Strap Handles

MULTI-GYM OPTIONS

- Colored Orthopedic Pads
- Colored Shroud
- Leg Press
- Ab Crunch Bar

Training Tips

CONSULT A PHYSICIAN BEFORE STARTING ANY EXERCISE PROGRAM

1. **Always warm up** before you start weight training. This helps get your muscles warm and prevents injury. You can warm up with light cardio or by doing a light set of each exercise before going to heavier weights.
2. **Control the weight.** Always work with a weight that you can handle through a full range of motion. Slow and steady movements are recommended.
3. **Breathe.** Don't hold your breath during your set. Holding your breath builds internal pressure which increases your chance for broken blood vessels, as well as a hernia.
4. **Sit up straight.** Pay attention to your posture and keep everything straight. Engage your abs in every movement to keep balanced and protect your spine.

GENERAL MAINTENANCE INFORMATION

Warning: DO NOT place styrofoam or printed materials on the orthopedic seat pads. Over time, these may stick to the pads and mar the surface.

Do not leave items sitting on the orthopedic seat pads, these pads have a special density that takes shape to objects and small objects will leave imprints in the surface that may take time to come out.

- Periodically inspect the cables for splitting, cracking or fraying. Also, watch for bulging or flat areas in the cable.
- Immediately replace cables at the first signs of damage or wear. Never use equipment with damaged or worn cables.
- Cables naturally stretch over time, so check cable slack periodically and adjust cable tension as needed.
- Regularly inspect product for loose hardware.
- Do not use or store equipment outdoors.
- Inspect snap links, swivels, handles, and weight stack pins for wear or damage. If wear or damage exists, replace immediately.
- Locate and familiarize yourself with all warning decals on the multi-gym.
- Replace damaged or worn upholstery immediately.
- Periodically wipe down guide rods with a dry cloth and re-apply a thin coat of a teflon-based lubricant.

MAINTENANCE SCHEDULE

ROUTINE	HOME MAINTENANCE	ENTRY DATE									
Inspect: Links, Pull Pins, Spring Clips, Swivels, Weight Stack Pins	WEEKLY										
Clean: Upholstery	WEEKLY										
Inspect: Cables and their Fittings	WEEKLY										
Inspect: Tautness of all Shrouds	WEEKLY										
Inspect: Accessory Bars and Handles	3 MONTHS										
Inspect: All Decals	3 MONTHS										
Inspect: All Nuts and Bolts. Tighten if Needed	3 MONTHS										
Inspect: Anti-Skid surfaces	3 MONTHS										
Clean and Lubricate: Guide Rods with a Teflon based lubricant	3 MONTHS										
Lubricate: Seat Sleeves and all Plastic Slides	3 MONTHS										
Clean and Wax: All Glossy Finishes	YEARLY										
Replace: Cables, Belts and Connecting Parts	2 YEARS										

INSPIRE

Warranty.

This Warranty applies to Inspire Strength products manufactured or distributed by Health In Motion LLC.

CONSUMER USE:

LIMITED LIFETIME FRAME:

Includes Frame and Welds

LIMITED LIFETIME PARTS:

Includes Upholstery, Hardware, etc.

LIMITED LIFETIME MOVING PARTS:

Includes Pulleys, Cables, etc.

LIGHT-COMMERCIAL USE:

LIMITED LIFETIME FRAME:

Includes Frame and Welds

10 YEAR PARTS:

Includes Upholstery, Hardware, etc.

10 YEAR MOVING PARTS:

Includes Pulleys, Cables, etc.

PLEASE NOTE THAT NOT ALL INSPIRE PRODUCTS ARE MADE FOR LIGHT-COMMERCIAL USE

Refer to your Owner's Manual or consult with your fitness product dealer to establish if a Product is made for light-commercial use or not. Using a non-commercial product in a commercial setting can result in serious injury or death!

Health In Motion warrants that the Product you have purchased for light-commercial, personal, family or household use from Health In Motion LLC or from an authorized Health In Motion reseller is free from defects in materials or workmanship under normal use during the warranty period. Your sales receipt, showing the date of purchase of the Product, is your proof of the date of purchase. This warranty extends only to you, the original purchaser. It is not transferable to anyone who subsequently purchases the Product from you. It excludes expendable parts such as paint and finish. This Warranty becomes VALID ONLY if the Product is assembled / installed according to the instructions / directions included with the Product.

Replacement and repair of parts.

During the warranty period Health In Motion will, at no additional charge, repair or replace the Product if it becomes defective, malfunctions, or otherwise fails to conform with this Warranty under normal light-commercial, personal, family, or household use. In repairing the product Health In Motion may replace defective parts with, at the option of Health In Motion, serviceable used parts that are equivalent to new parts in performance, or new parts. All exchanged parts and Products replaced under this warranty will become the property of Health In Motion. Health In Motion reserves the right to change manufacturers and or specification of any part to cover any existing warranty.

Service procedures.

To obtain warranty parts, you must return the parts to Health In Motion or an authorized Health In Motion retailer in its original container (or equivalent). You must pre-pay any shipping charges, taxes, or any other charges associated with transportation of the Product. In addition, you are responsible for insuring any Product shipped or returned. You assume the risk of loss during shipment. You must present Health In Motion with proof-of-purchase documents (including the date of purchase, Model, and Serial Number). Any evidence of alteration, erasing or forgery of proof-of-purchase documents will be cause to void this Warranty. Register your warranty online visit www.inspirefitness.net

Conditions and Exceptions.

This Warranty does not extend to any Product not purchased from Health In Motion LLC or from an authorized Health In Motion reseller. This Warranty does not extend to any Product that has been damaged or rendered defective; (a) as a result of accident, misuse, or abuse; (b) by the use of parts not manufactured or sold by Health In Motion; (c) by modification of the Product; (d) as a result of service by anyone other than Health In Motion, or an authorized Health In Motion warranty service provider; (e) product that has not been properly maintained (follow maintenance schedule found on product). Should any product submitted for Warranty service be found to be ineligible, an estimate of repair cost will be furnished and the repair will be made if requested by you upon Health In Motion receipt of payment or acceptable arrangement of payment.

Disclaimer

EXCEPT AS EXPRESSLY SET FORTH IN THIS WARRANTY HEALTH IN MOTION MAKES NO OTHER WARRANTIES; EXPRESSED OR IMPLIED INCLUDING ANY IMPLIED WARRANTIES OF MERCHANTABILITY AND FITNESS FOR A PARTICULAR PURPOSE. HEALTH IN MOTION EXPRESSLY DISCLAIMS ALL WARRANTIES NOT STATED IN THIS WARRANTY. ANY IMPLIED WARRANTIES THAT MAY BE IMPOSED BY LAW ARE LIMITED TO THE TERMS OF THIS WARRANTY. NEITHER HEALTH IN MOTION NOR ANY OF ITS AFFILIATES SHALL BE RESPONSIBLE FOR INCIDENTAL OR CONSEQUENTIAL DAMAGES. HEALTH IN MOTION IS NOT RESPONSIBLE FOR THE REPAIR OR REPLACEMENT OF ANY PARTS THAT HEALTH IN MOTION DETERMINES HAVE BEEN SUBJECTED AFTER THE DATE OF MANUFACTURE TO ALTERATION, NEGLIGENCE, ABUSE, MISUSE, NORMAL WEAR & TEAR, ACCIDENT, DAMAGE DURING TRANSIT OR INSTALLATION, FIRE, FLOOD, OR ANY ACT OF GOD. SOME STATES DO NOT ALLOW LIMITATIONS ON HOW LONG AN IMPLIED WARRANTY LASTS OR THE EXCLUSION OR LIMITATION OF INCIDENTAL OR CONSEQUENTIAL DAMAGES, SO THE ABOVE LIMITATIONS OR EXCLUSION MAY NOT APPLY TO YOU. This Warranty gives you specific legal rights and you may also have other rights that may vary from state to state. This is the only express warranty applicable to Health In Motion's "Inspire" branded strength products. Health In Motion neither assumes nor authorizes anyone to assume for it any other express warranty.